

e935

Bedienungsanleitung
Instruction Manual
Notice d'emploi
Istruzioni per l'uso
Instrucciones para el uso
Gebruiksaanwijzing



 **evolution**

Bedienungsanleitung	3
Instruction Manual	7
Notice d'emploi	11
Istruzioni per l'uso	15
Instrucciones para el uso	19
Gebruiksaanwijzing	23

935

Hochwertiges dynamisches Mikrofon mit Nierencharakteristik. Besonders durchsetzungsstarke Akustik auf lauten Bühnen.

Merkmale

- einzigartige Feedback-Sicherheit
- extrem robust für den rauen Bühnenalltag
- um 3–6 dB erhöhtes „Gain before Feedback“
- durchsetzungsfähiger, druckvoller Sound bei Vocals
- integriertes Shock-mount

Lieferumfang

Mikrofon  935

Klammer MZQ 800 Art.-Nr. 4711

Tasche

Bedienungsanleitung

Garantiekarte

Besprechen

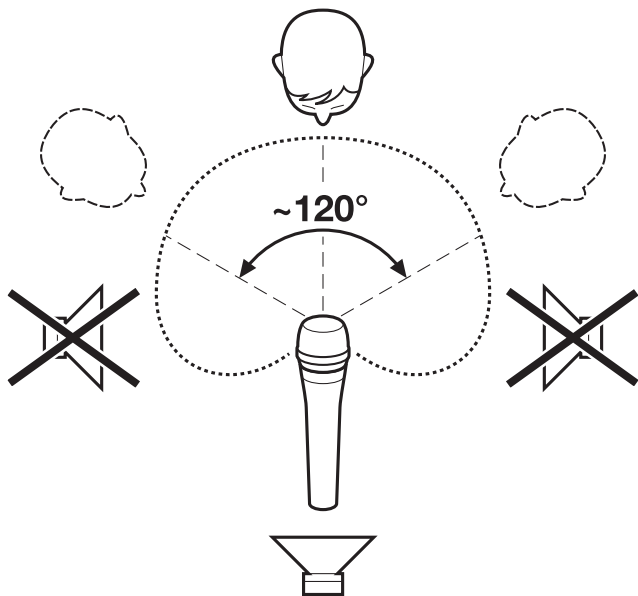

Mikrofonanschluss

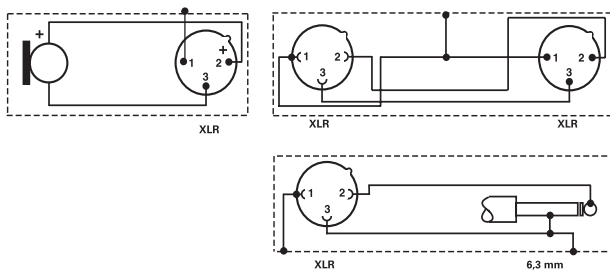
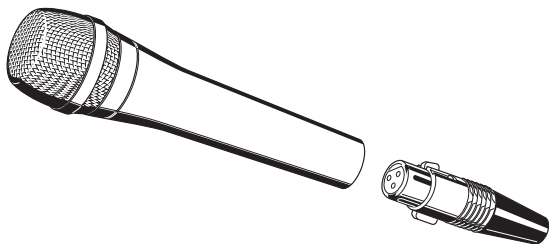

Einsprachekorb abdrehen



Technische Daten

Wandlerprinzip	dynamisch
Akustische Arbeitsweise	Druckgradientenempfänger
Übertragungsbereich	40–18.000 Hz
Richtcharakteristik	Niere
Freifeldleerlauf- Übertragungsfaktor (bei 1 kHz)	2,8 mV/Pa \pm 3 dB
Magnetfeldstörfaktor (bei 50 Hz)	$\leq 1\mu\text{V}/\mu\text{T}$
Nennimpedanz (bei 1 kHz)	350 Ω
Min. Abschlussimpedanz	1 k Ω
Rückwärtsdämpfung (bei 1 kHz und 180°)	> 20 dB
Stecker	3-polig XLR-3-Stecker
Gewicht	355 g
Maße	\varnothing 46,6 mm, Länge 181 mm

e935

High-quality dynamic vocal microphone with cardioid pick-up pattern, specially designed to ensure vocals cut through high on-stage sound levels.

Features

- Exceptional feedback rejection
- Extremely rugged for rough stage use
- "Gain before feedback" increased by 3-6 dB
- Powerful sound with presence boost for improved vocal projection
- Integral shock mount

Delivery includes

e935 microphone

MZQ 800 microphone clamp Cat. No. 4711

Pouch

Instruction manual

Guarantee Certificate

Sound pick-up

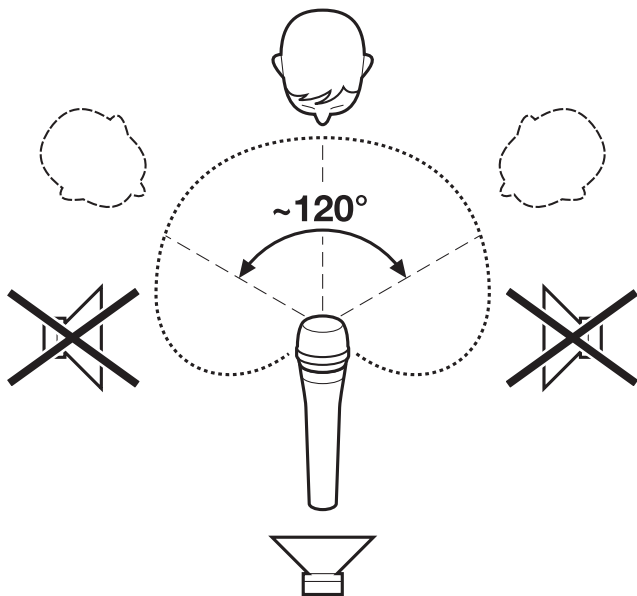

Connection details

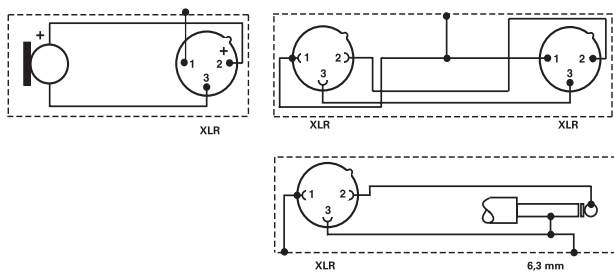
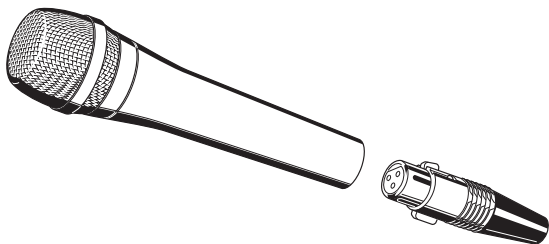

Removing the sound inlet basket



Specifications

Transducer principle	dynamic
Acoustic operating principle	pressure gradient receiver
Frequency response	40–18,000 Hz
Pick-up pattern	cardioid
Sensitivity (free field, no load) (at 1 kHz)	2.8 mV/Pa \pm 3 dB
Magnetic field interference factor (at 50 Hz)	$\leq 1\mu\text{V}/\mu\text{T}$
Nominal impedance (at 1 kHz)	350 Ω
Min. terminating impedance	1 k Ω
Front-to-back rejection (at 1 kHz and 180°)	> 20 dB
Connector	XLR-3
Weight	355 g
Dimensions	diameter: 46.6 mm, length: 181 mm

935

Microphone dynamique de haute qualité, de directivité cardioïde. Il assure une projection vocale optimale, même sur les scènes où règne un niveau sonore élevé.

Points forts

- Exceptionnelle réjection du Larsen
- Très grande robustesse, pour résister aux rigueurs des concerts
- « Gain avant Larsen » accru de 3 à 6 dB
- Son d'une grande puissance, avec une bosse de présence améliorant la projection sur les voix
- Suspension élastique intégrée

L'emballage contient

Microphone  935

Pince MZQ 800 N° Réf. 4711

Etui

Notice d'emploi

Document de garantie

Directivité – zone de couverture

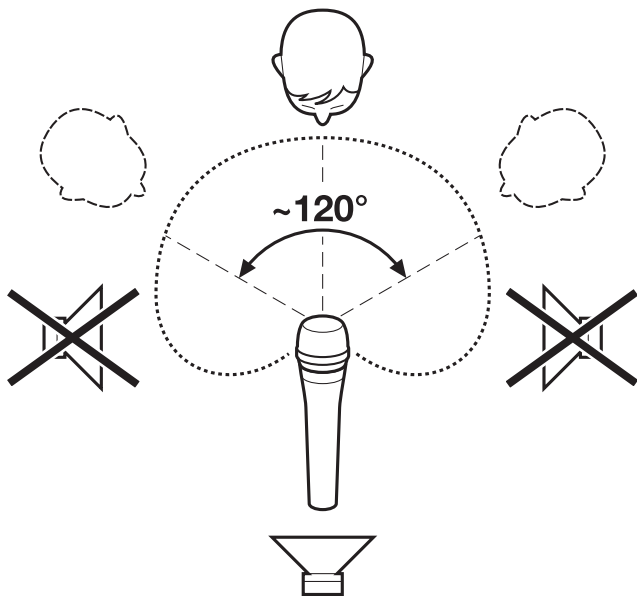

Connexion du microphone

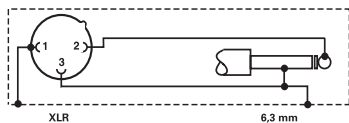
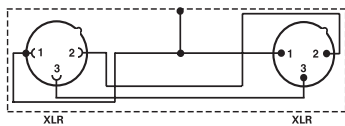
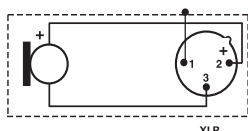
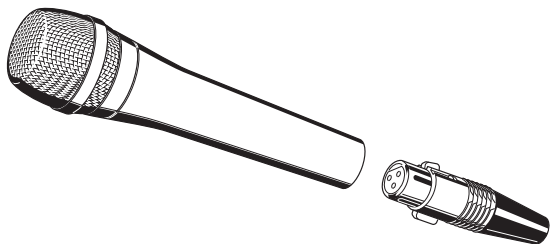

Démontage de la tête de microphone



Caractéristiques techniques

Principe transducteur	dynamique
Principe acoustique de fonctionnement	gradient de pression
Réponse en fréquence	40–18.000 Hz
Directivité	cardioïde
Sensibilité (champ libre, à vide) (à 1 kHz)	2,8 mV/Pa \pm 3 dB
Sensibilité aux champs magnétiques (à 50 Hz)	$\leq 1\mu\text{V}/\mu\text{T}$
Impédance nominale (à 1 kHz)	350 Ω
Impédance de charge minimale	1 k Ω
Réjection arrière (à 1 kHz et 180°)	> 20 dB
Connecteur	XLR-3, 3 contacts
Poids	355 g
Dimensions	diamètre : 46,6 mm, longueur : 181 mm

e935

Microfono dinamico cardioide di qualità elevata.
Acustica particolarmente intensa su palchi dalla sonorità elevata.

Caratteristiche

- straordinaria protezione contro il feedback
- massima robustezza per il duro lavoro quotidiano sul palco
- "Gain before Feedback" aumentato di 3–6 dB
- suono potente e intenso per il canto
- schockmount integrato

Dotazione di fornitura

Microfono **e935**

Dispositivo di fissaggio MZQ 800 N. art. 4711

Custodia

Istruzioni per l'uso

Scheda di garanzia

Raggio di azione

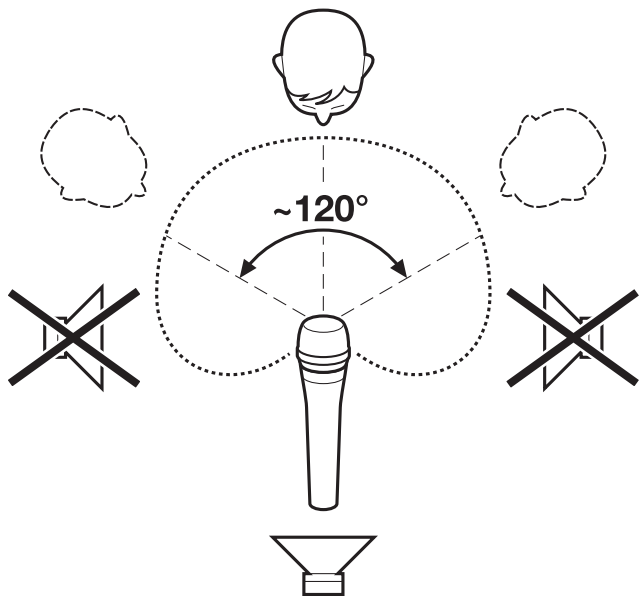

Collegamento del microfono

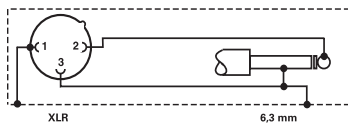
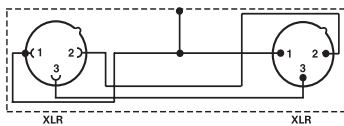
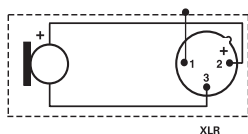
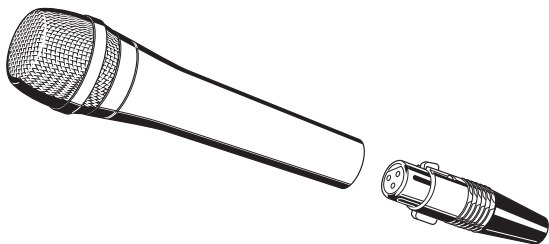

Svitare la testa del microfono



Dati tecnici

Principio di funzionamento	dinamico
Principio di funzionamento	a gradiente di pressione
Risposta in frequenza	40–18.000 Hz
Direttività	cardioide
Sensibilità (in campo libero, senza carico) ad 1 kHz	2,8 mV/Pa \pm 3 dB
Sensibilità ai campi magnetici (a 50 Hz)	$\leq 1\mu\text{V}/\mu\text{T}$
Impedenza nominale (ad 1 kHz)	350 Ω
Impedenza minima di carico	1 k Ω
Attenuazione avanti/indietro (ad 1 kHz e 180°)	> 20 dB
Connettore	connettore XLR-3 a 3 poli
Peso	355 g
Dimensioni	\varnothing 46,6 mm, lunghezza 181 mm

e935

Micrófono dinámico de alta calidad con característica cardioide. Acústica especialmente potente en escenarios ruidosos.

Características

- extraordinaria seguridad contra el reacoplamiento
- extremadamente robusto para el uso duro en el escenario
- "Gain before Feedback" aumentado en 3-6 dB
- sonido potente y pleno para voz
- montado a prueba de sacudidas

Volumen de suministro

Micrófono  e935

Pinza MZQ 800 nº art. 4711

Bolsa

Instrucciones para el uso

Tarjeta de garantía

Hablar

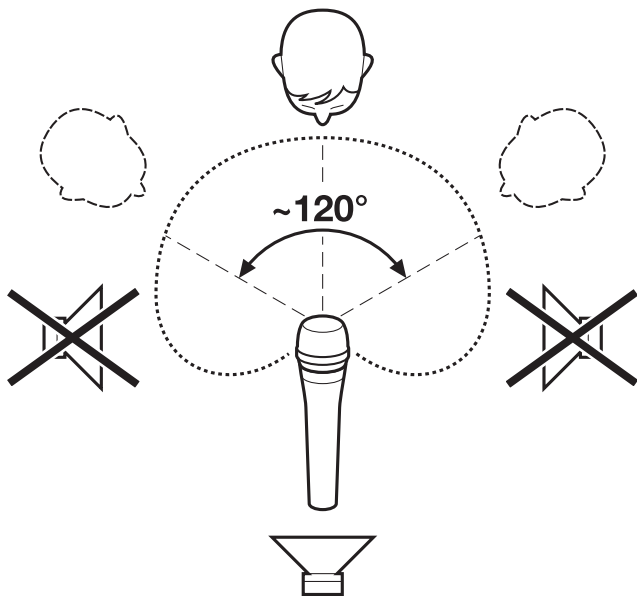

Conexión de micrófono

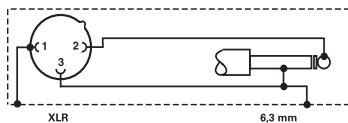
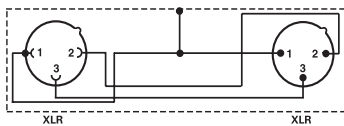
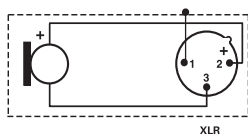
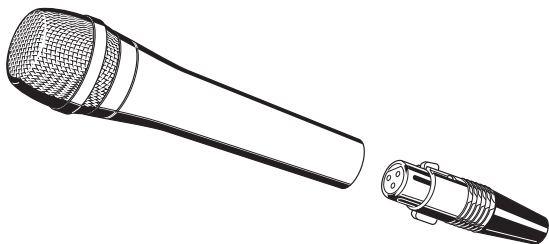

Desmontaje de cesto de registro



Datos técnicos

Principio transductor	dinámico
Modo acústico	Receptor de gradiente de presión
Respuesta	40–18.000 Hz
Característica direccional	cardioide
Factor de transmisión neutro en campo libre (con 1 kHz)	2,8 mV/Pa \pm 3 dB
Factor de interferencia de campo magnético (con 50 Hz)	$\leq 1\mu\text{V}/\mu\text{T}$
Impedancia nominal (con 1 kHz)	350 Ω
Impedancia terminal mín.	1 k Ω
Atenuación inversa (con 1 kHz y 180°)	> 20 dB
Conector	Conector XLR-3 de 3 polos
Peso	355 g
Dimensiones	\varnothing 46,6 mm, largo 181 mm

e935

Hoogwaardige dynamische microfoon met nierkarakteristiek. Bijzonder vaste en krachtige akoestiek bij luide optredens.

Eigenschappen

- unieke feedback-betrouwbaarheid
- extreem robuust t.b.v. de meest zware podiumomstandigheden
- met 3 – 6 dB verhoogde "Gain voor Feedback"
- krachtig, indrukwekkend geluid voor zangtoepassing
- geïntegreerde verende ophanging

Omvang levering

Microfoon **e935**

Klem MZQ 800 Art.-Nr. 4711

Hoes

Gebruiksaanwijzing

Garantiebewijs

Vergaderen

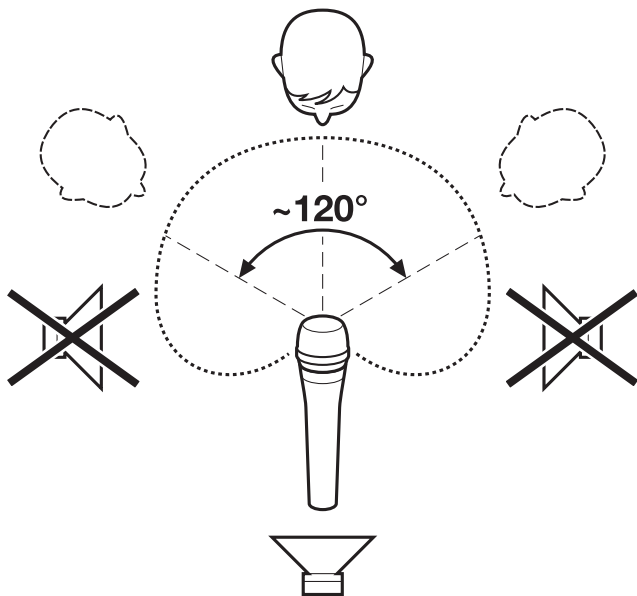

Microfoonaansluiting

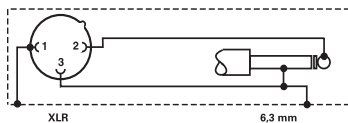
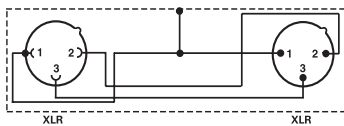
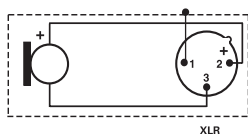
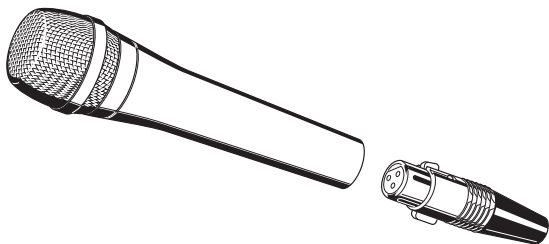

Spreekorf losdraaien



Technische gegevens

Omvormerprincipe	dynamisch
Akoestische werking	drukgradiënt
Frequentiebereik	40–18.000 Hz
Richtkarakteristiek	Nier
Onbelaste werking	
Frequentiefactor veld (bij 1 kHz)	2,8 mV/Pa \pm 3 dB
Storingsfactor magneetveld (bij 50 Hz)	$\leq 1\mu\text{V}/\mu\text{T}$
Nom. impedantie (bij 1 kHz)	350 Ω
Min. afsluitimpedantie	1 k Ω
Achterwaartse demping (bij 1 kHz en 180°)	> 20 dB
Stekker	3-polige XLR-3-stekker
Gewicht	355 g
Afmeting	\varnothing 46,6 mm, lengte 181 mm

Soll-Frequenzgang
 Nominal Frequency response
 Courbe de réponse
 Risposta armonica nominale
 Respuesta nominal
 Streefwaarde-Frequentiearakteristiek

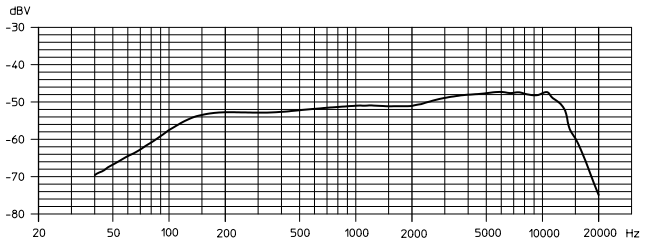

Polardiagramm
 Pick-up pattern
 Diagramme de la directivité
 Diagramma polare
 Diagrama de la directividad
 Polardiagram

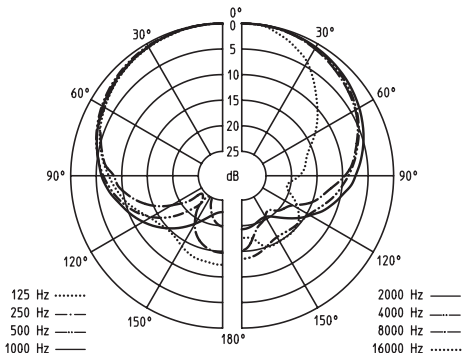



Konformitätserklärung

Sennheiser electronic GmbH & Co. KG erklären, dass dieses Gerät die anwendbaren CE-Normen und Vorschriften erfüllt.

Approval

Sennheiser electronic GmbH & Co. KG declare that this device is in compliance with the applicable CE standards and regulations.

Certification

Sennheiser electronic GmbH & Co. KG déclarons que cet appareil est en conformité avec les normes CE.

Certificazione

Sennheiser electronic GmbH & Co. KG dichiara che questo apparecchio risponde alle normative e alle prescrizioni CE applicabili.

Autorizacion

Sennheiser electronic GmbH & Co. KG declara que este aparato cumple las normas y directrices de la CE aplicables.

Vergunning

Sennheiser electronic GmbH & Co. KG verklaren, dat dit toestel voldoet aan de toepasselijke CE-normen en voorschriften.

Diese Service-Nummer gilt nur für Deutschland



K.I.S.S.

Kunden-Informations-System-Sennheiser

0180 / 5221 539

0,12 € je Minute

Montag -Freitag: 8.00 Uhr - 18.00 Uhr

