

# Tourguide System 2020



# Contents

|   |    |
|---|----|
| Important safety instructions .....   | 2  |
| System components .....   | 7  |
| Overview of the system .....  | 8  |
| The operating controls .....  | 10 |
| Indications and displays on the bodypack transmitter .....                                    | 15 |
| Indications and displays on the radio microphone .....  | 17 |
| Indications and displays on the receiver .....  | 19 |
| Indications and displays on the charging case .....   | 21 |
| The functions of the operating controls of the bodypack<br>transmitter/radio microphone ..... | 23 |
| The functions of the operating controls of the receivers .....                                | 24 |
| The functions of the operating controls of the charging case .....                            | 24 |
| Putting the components into operation .....   | 25 |
| Using the components .....  | 29 |
| Switching the devices on/off .....  | 29 |
| Adjusting the volume .....  | 31 |
| Charging the rechargeable batteries .....   | 32 |
| Setting a channel .....   | 35 |
| Muting the devices .....  | 39 |
| Special bodypack transmitter/radio microphone settings .....                                  | 40 |
| The operating menu of the bodypack transmitter/radio microphone .....                         | 48 |
| Overview of the bodypack transmitter's operating menu .....                                   | 49 |
| Overview of the radio microphone's operating menu .....                                       | 51 |
| Care and maintenance .....  | 53 |
| If a problem occurs... ..   | 54 |
| Specifications .....  | 55 |
| Accessories .....   | 58 |
| Manufacturer declarations .....   | 59 |
| Index .....   | 62 |

Thank you for choosing Sennheiser!

We have designed this product to give you reliable operation over many years. Over 60 years of accumulated expertise in the design and manufacture of high-quality electro-acoustic equipment have made Sennheiser a world-leading company in this field.

Please take a few moments to read these instructions carefully, as we want you to enjoy your new Sennheiser products quickly and to the fullest.

# Important safety instructions

- Read these instructions.
- Keep these instructions.
- Heed all warnings.
- Follow all instructions.
- Do not use this apparatus near water.
- Clean only with dry cloth.
- Do not block any ventilation openings. Install in accordance with the manufacturer's instructions.
- Do not install near any heat sources such as radiators, heat registers, stoves, or other apparatus (including amplifiers) that produce heat.
- Do not defeat the safety purpose of the polarized or grounding-type plug. A polarized plug has two blades with one wider than the other. A grounding type plug has two blades and a third grounding prong. The wide blade or the third prong are provided for your safety. If the provided plug does not fit into your outlet, consult an electrician for replacement of the obsolete outlet.
- Protect the power cord from being walked on or pinched, particularly at plugs, convenience receptacles, and the point where they exit from the apparatus.
- Only use attachments/accessories specified by the manufacturer.
- Use only with the cart, stand, tripod, bracket, or table specified by the manufacturer, or sold with the apparatus. When a cart is used, use caution when moving the cart/apparatus combination to avoid injury from tip-over.
- Unplug this apparatus during lightning storms or when unused for long periods of time.
- Refer all servicing to qualified service personnel.  
Servicing is required when the apparatus has been damaged in any way, such as power supply cord or plug is damaged, liquid has been spilled or objects have fallen into the apparatus, when the apparatus has been exposed to rain or moisture, does not operate normally, or has been dropped.
- Use all-pole mains switch to disconnect the apparatus from the mains.
- **WARNING:** To reduce the risk of fire or electric shock, do not expose this apparatus to rain or moisture.
- Do not expose this equipment to dripping or splashing and ensure that no objects filled with liquids, such as vases, are placed on the equipment.
- The mains plug of the power supply cord shall remain readily operable.
- **WARNING:** Do not expose batteries or battery pack to excessive heat such as sunshine, fire or the like.
- **Caution:** Danger of explosion if battery is incorrectly replaced. Replace only with the same or equivalent type.



## Hazard warnings on the EZL 2020-20 L charging case



The label shown on the left is attached to the rear of the charging case. The symbols on this label have the following meaning:



This symbol is intended to alert the user to the presence of uninsulated dangerous voltage within the device's enclosure that may be of sufficient magnitude to constitute risk of fire or electric shock.



This symbol is intended to alert the user to the risk of electric shock if the device is opened. There are no user serviceable parts inside. Refer servicing to qualified personnel only.



This symbol indicates the presence of important operating and maintenance instructions in the literature accompanying this device.

## Overloading

Do not overload wall outlets and extension cables as this may result in fire and electric shock.

## Replacement parts

When replacement parts are required, be sure the service technician uses replacement parts specified by Sennheiser or those having the same characteristics as the original part. Unauthorized substitutions may result in fire, electric shock, or other hazards.

## Safety check

Upon completion of any service or repairs to this device, ask the service technician to perform safety checks to determine that the devices are in a safe operating condition.

### Danger of hearing damage due to high volumes

This is a professional transmission system. Commercial use is subject to the rules and regulations of the trade association responsible. Sennheiser, as the manufacturer, is therefore obliged to expressly point out possible health risks arising from use.

The HDE 2020 D and EK 2020 D receivers are capable of producing sound pressure exceeding 85 dB(A). 85 dB(A) is the sound pressure corresponding to the maximum permissible volume which is by law (in some countries) allowed to affect your hearing for the duration of a working day. It is used as a basis according to the specifications of industrial medicine. Higher volumes or longer durations can damage your hearing. At higher volumes, the duration must be shortened in order to prevent hearing damage. The following are sure signs that you have been subjected to excessive noise for too long a time:

- You can hear ringing or whistling sounds in your ears.
- You have the impression (even for a short time only) that you can no longer hear high notes.

### Intended use of the devices

Intended use includes:

- using the devices for professional purposes,
- having read this instruction manual, especially the chapter "Important safety instructions" on page 2,
- using the devices within the operating conditions and limitations described in this instruction manual.

"Improper use" means using the devices other than as described in this instruction manual, or under operating conditions which differ from those described herein.

### Safety instructions for Li-Polymer and Ni-

MH rechargeable batteries and batteries

If abused or misused, rechargeable batteries may leak. In extreme cases, they may even present:

**CAUTION!**

- a heat hazard,
- a fire hazard,
- an explosion hazard,
- a smoke or gas hazard.



Sennheiser does not accept any liability for damage arising from abuse or misuse.



Keep away from children.



Observe correct polarity.



Do not heat above 70°C/ 158°F, e.g. do not expose to sunlight or throw into a fire.



Switch rechargeable battery-powered devices off after use.



Do not expose to moisture.



Only charge rechargeable batteries with the appropriate Sennheiser chargers.



Do not short-circuit.



When not using rechargeable batteries for extended periods of time, charge them regularly (about every three months).



Do not mutilate or dismantle.



Only charge rechargeable batteries at ambient temperatures between 10°C/50°F and 40°C/104°F.



Do not pack charged batteries loose – danger of shorting out / fire hazard.



Immediately remove rechargeable batteries from obviously defective devices.



Do not continue to use defective rechargeable batteries.



Dispose of rechargeable batteries and devices with built-in rechargeable batteries at special collection points or return them to your specialist dealer.



Only use original Sennheiser rechargeable batteries.

**Additional safety instructions for the BA 2015 accupack and for batteries**



Do not solder.



Immediately remove flat batteries/  
rechargeable batteries from the  
device.

Rechargeable batteries must only be replaced by authorized Sennheiser partners.  
If abused or misused, rechargeable batteries may be damaged!

# System components

The Tourguide System 2020 D consists of the following components which are available from your Sennheiser partner:

- EZL 2020-20 L charging case including instruction manual of the overall system
- SK 2020 D bodypack transmitter
- SKM 2020 D radio microphone
- HDE 2020 D stethoset receiver
- EK 2020 D receiver
- BA 2015 accupack
- Mains cable
- Microphone (see next section)

# Overview of the system

The Tourguide System 2020 D offers optimum digital speech transmission for conferences and guided tours e.g. in factories or museums. The use of RF transmission allows freedom of movement for all members of the group. Six preset intermodulation-free receiving frequencies offer high flexibility and adaptability.

The Tourguide System 2020 D operates in the 863 MHz – 865 MHz frequency band, which is license-free in Europe. For an overview, refer to page 56.

## SK 2020 D bodypack transmitter

You can connect one of the following Sennheiser microphones (to be ordered separately) to the bodypack transmitter:

- Clip-on microphones:  
ME 2-N, ME 4-N, MKE 2-EW GOLD
- Headmics:  
ME 3-N, HSP 2-EW, HSP 4-EW, HS 2-EW
- Hand-held microphones with  
special connecting cable:  
e 815, e 825 S, e 835, e 840, e 845

In addition, you can connect any audio source (e.g. a flash / MP3 player) to the bodypack transmitter.

## SKM 2020 D radio microphone

This extremely rugged radio microphone can be used in various tour situations. The radio microphone is easy to configure and use.

For storage and safe transportation, the radio microphone can be placed in the charging case and secured with Velcro tape.

## HDE 2020 D and EK 2020 D receivers

The receivers are easy to use and comfortable to wear. The built-in LC display shows all the important information at a glance (receiving channel, reception quality, charge status of the built-in Lithium-polymer rechargeable battery as well as the currently set volume). The rocker button allows fast and easy setting of the desired channel.

The EK 2020 D allows you to connect any headphones or an induction loop for wearers of hearing aids.

The system can be expanded at any time by adding additional receivers.

## EZL 2020-20 L charging case

The charging case simultaneously recharges up to 20 stetho-set receivers with their built-in rechargeable batteries, as well as the BA 2015 accupack of the bodypack transmitter/radio microphone. You can also charge the bodypack transmitter with the BA 2015 accupack inserted plus an additional spare accupack. The channel copy function lets you set all receivers to the same channel at the press of a button.

Additional features of the charging case:

- Quick charge of accupacks.
- Automatic detection of full charge and subsequent switching to trickle charging so the accupacks can remain in the charger even when they have been fully charged.
- Highest possible operational reliability, since temperature and voltage of the accupacks are monitored during charging.
- Long accupack service life due to overcharge protection and recovery of deep-discharged accupacks.
- Safe storage and transportation of the system components.

# The operating controls

## SK 2020 D bodypack transmitter

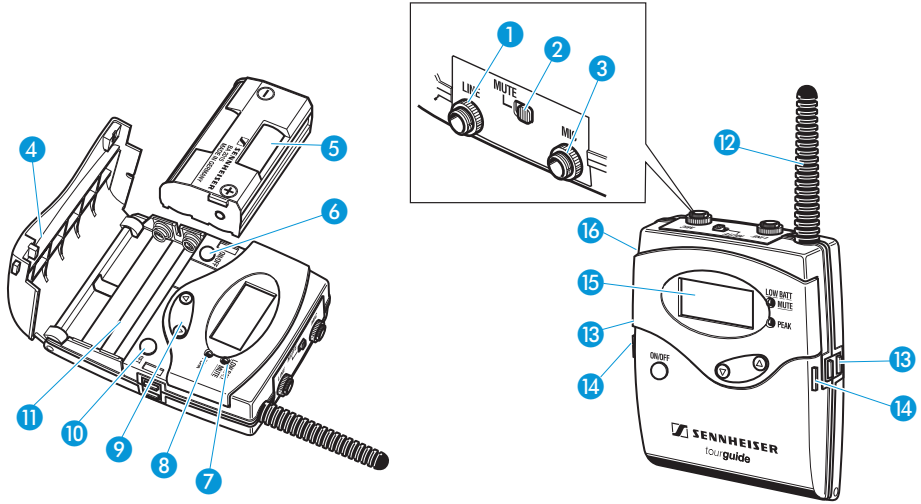

- ① Line input
- ② MUTE switch
- ③ Microphone input
- ④ Battery compartment cover
- ⑤ BA 2015 accupack
- ⑥ ON/OFF button  
(under battery compartment cover)
- ⑦ Red LED LOW BATT/MUTE
- ⑧ Yellow LED PEAK
- ⑨ ▲/▼ rocker button
- ⑩ SET button  
(under battery compartment cover)
- ⑪ Battery compartment
- ⑫ Antenna
- ⑬ Charging contacts
- ⑭ Battery compartment catches
- ⑮ LC display
- ⑯ Belt clip  
(on the back of the transmitter)

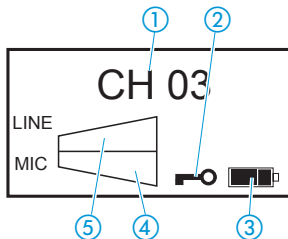

- ① Channel display
- ② Lock mode icon
- ③ 4-step battery status indication
- ④ MIC level display
- ⑤ LINE level display

## SKM 2020 D radio microphone

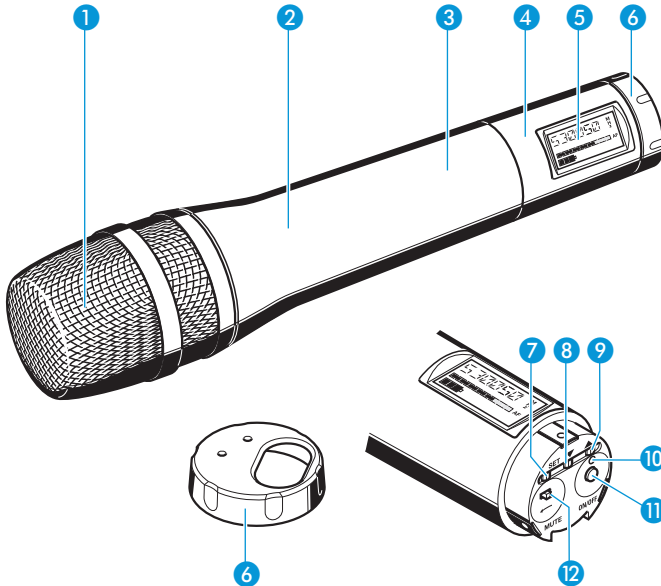

- ① Sound inlet basket
- ② Body of radio microphone
- ③ Battery compartment (not visible from outside)
- ④ Display section
- ⑤ LC display
- ⑥ Turnable protective cap for operating controls (shown removed); the following operating controls become accessible in turn by turning the protective cap:
  - ⑦ SET button
  - ⑧ ▼ button
  - ⑨ ▲ button
  - ⑩ Operation / battery status indicator, red LED (ON/LOW BATT)
  - ⑪ ON/OFF button with ESC function (cancel) in the operating menu
  - ⑫ MUTE switch

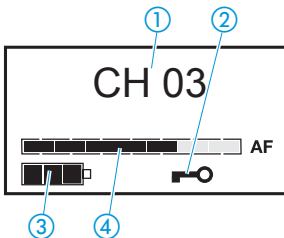

- ① Channel display
- ② Lock mode icon
- ③ 4-step battery status indication
- ④ 7-step audio level display "AF"

## HDE 2020 D stethoset receiver

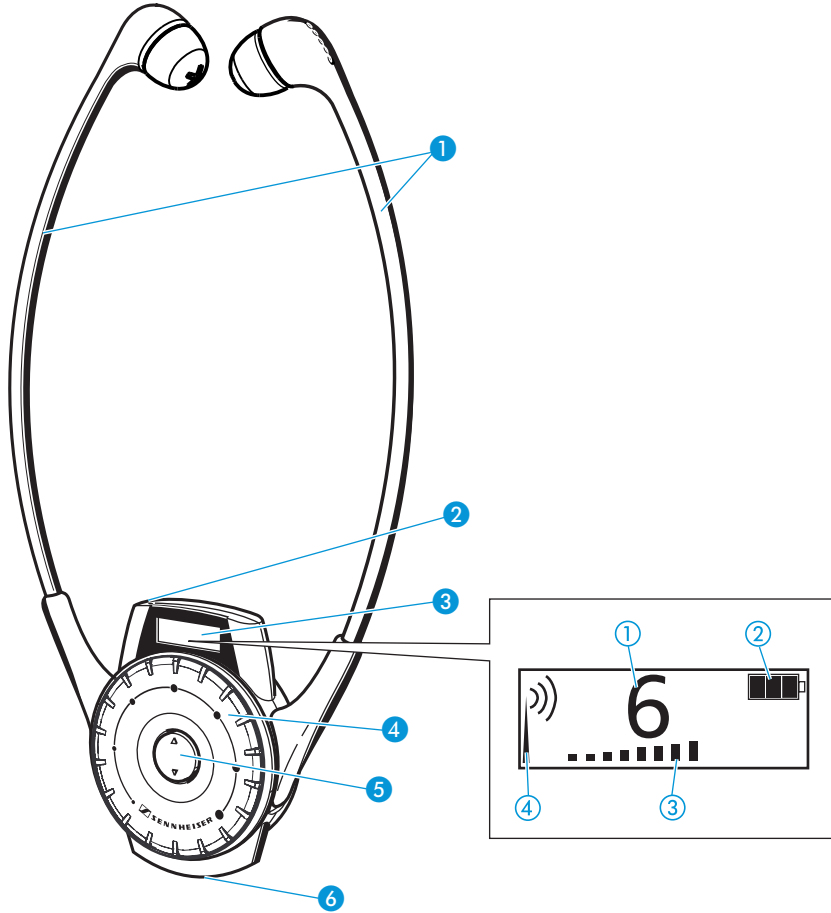

- ① Earbuds
- ② Red/green LED for charge status
- ③ LC display
- ④ Volume control
- ⑤ Channel selection button ▲/▼
- ⑥ Charging contacts

- ① Channel display
- ② 4-step battery status display
- ③ Volume display
- ④ RF signal indication

EK 2020 D receiver

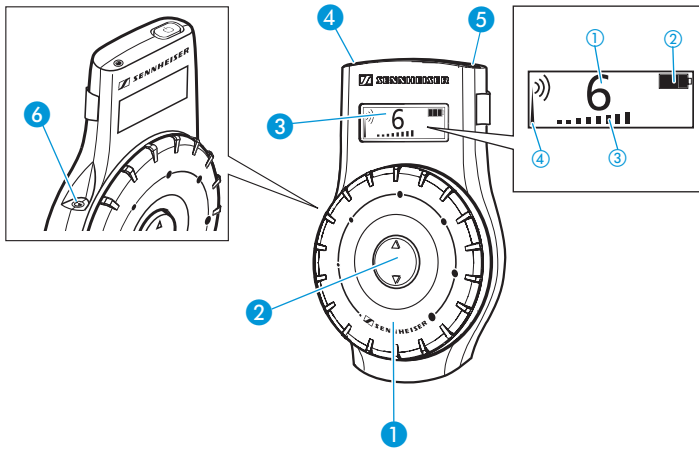

- ① Volume control
- ② Channel selection button ▲/▼
- ③ LC display
- ④ LED for charge status
- ⑤ ON/OFF button ⏻
- ⑥ Headphone socket

- ① Channel display
- ② 4-step battery status display
- ③ Volume display
- ④ RF signal indication

## EZL 2020-20 L charging case

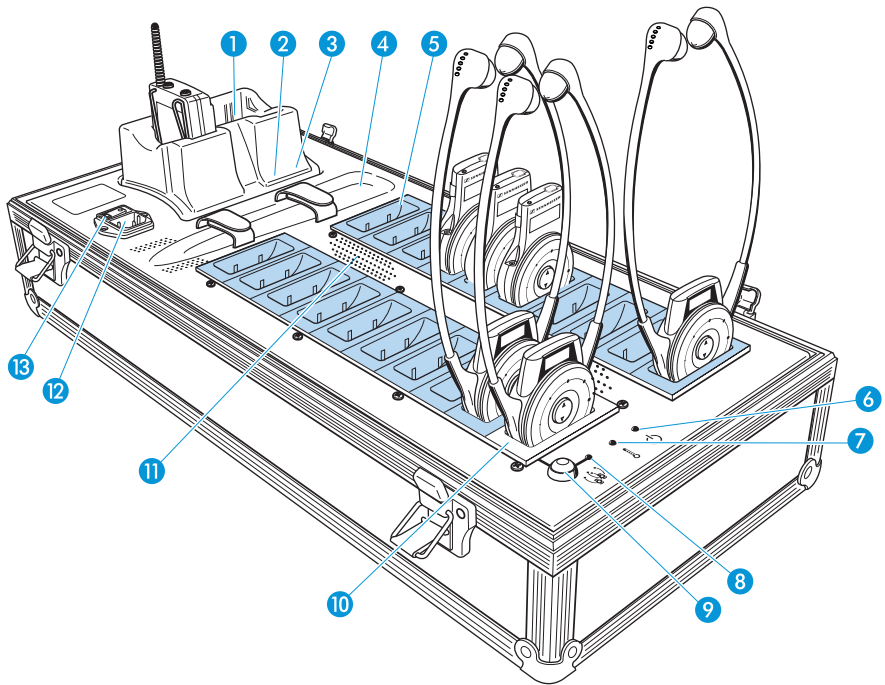

- 1 Charging compartments for accupack/bodypack transmitter
- 2 Red LED CHARGE/ERROR
- 3 Green LED READY
- 4 Storage place for radio microphone
- 5 19 charging compartments for receivers (slaves, light blue in the diagram)
- 6 LED POWER
- 7 LED TEMP ERROR
- 8 LED COPY AVAILABLE
- 9 COPY button
- 10 Charging compartment with channel copy function (master)
- 11 Air vents
- 12 IEC mains socket
- 13 Mains switch

## Indications and displays on the bodypack transmitter

### Operation and battery status indication

The red LED **LOW BATT/MUTE** ⑦ provides information on the current operating state of the bodypack transmitter:

#### Red LED off:

The bodypack transmitter is switched on and the capacity of the batteries/BA 2015 accupack is sufficient.

#### Red LED flashing:

The batteries are/the BA 2015 accupack is going flat (LOW BATT).

In addition, the 4-step battery status display ③ on the display panel provides information on the remaining battery/BA 2015 accupack capacity:

|                       |                       |
|-----------------------|-----------------------|
| 3 segments            | capacity approx. 100% |
| 2 segments            | capacity approx. 70%  |
| 1 segments            | capacity approx. 30%  |
| Battery icon flashing | LOW BATT              |

### AF peak indication

The yellow LED **PEAK** ⑧ lights up when the transmitter's audio input is overmodulated.

If the transmitter's audio input level is excessively high, the sound of the receivers may be distorted. In order to avoid distortion in the receivers, reduce the sensitivity of the transmitter's line and/or microphone input (see "Changing the sensitivity of the bodypack transmitter's line input" on page 41 and "Changing the sensitivity of the bodypack transmitter's microphone input" on page 42).

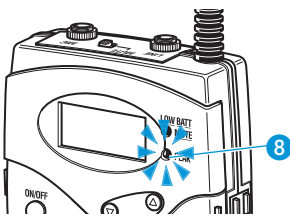
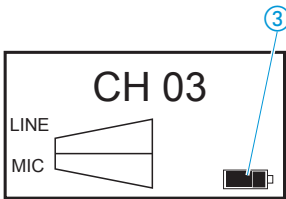
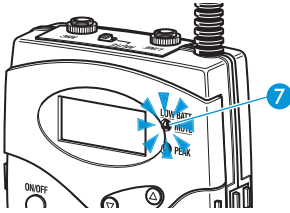

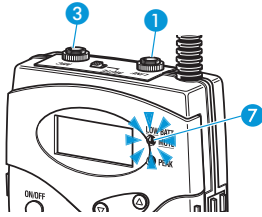

### MUTE display

The red LED **LOW BATT/MUTE** 7 lights up when the transmitter's microphone input is muted (see "Muting the devices" on page 39).

#### Note:

The muting function (MUTE) mutes the microphone input 3 only, not the line input 1.

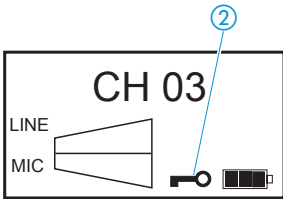

### Lock mode icon

The lock mode icon 2 appears on the display when the lock mode is activated (see "Activating/deactivating the lock mode" on page 45).

### Display backlighting

After pressing a button, the display remains backlit for approx. 30 seconds.

### Display of the energy saving mode

When there is no audio signal for 5 minutes or when the bodypack transmitter is muted, it automatically switches to energy saving mode. "CH OFF" appears on the display and the transmission signal is deactivated.

When an audio signal reaches the bodypack transmitter, it automatically switches back to normal operation and the display displays the selected channel.

## Indications and displays on the radio microphone

### Operation and battery status indication

The red LED (LOW BATT/ON) ⑩ provides information on the current operating state of the radio microphone:

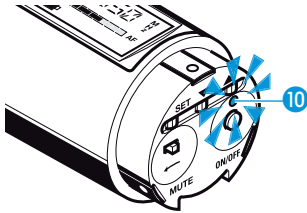

#### Red LED off:

The radio microphone is switched on and the capacity of the batteries/BA 2015 accupack is sufficient.

#### Red LED flashing:

The batteries are/the BA 2015 accupack is going flat (LOW BATT)!

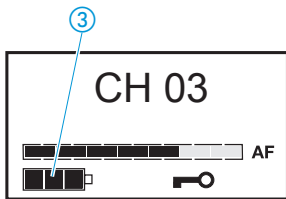

In addition, the 4-step battery status display ③ on the display panel provides information on the remaining battery/BA 2015 accupack capacity:

|                       |                       |
|-----------------------|-----------------------|
| 3 segments            | capacity approx. 100% |
| 2 segments            | capacity approx. 70%  |
| 1 segments            | capacity approx. 30%  |
| Battery icon flashing | LOW BATT              |

#### Lock mode icon

The lock mode icon ② appears on the display when the lock mode is activated (see "Activating/deactivating the lock mode" on page 45).

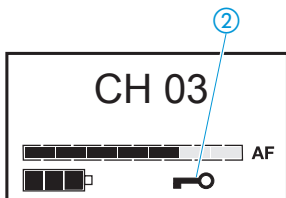

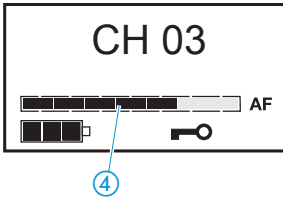

### Modulation display

The level display for audio signal "AF" ④ shows the modulation of the radio microphone.

When the radio microphone's audio input level is excessively high, the level display for audio signal "AF" ④ shows full deflection for the duration of the overmodulation. You can change modulation by changing the input sensitivity of the radio microphone as described on page 43.

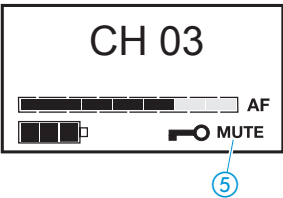

### MUTE display

When the radio microphone is muted, "MUTE" ⑤ appears on the display (see "Muting the radio microphone" on page 39).

### Display backlighting

After pressing a button, the display remains backlit for approx. 15 seconds.

### Display of the energy saving mode

When there is no audio signal for 5 minutes or when the radio microphone is muted, it automatically switches to energy saving mode. "CH OFF" appears on the display and the transmission signal is deactivated.

When an audio signal reaches the radio microphone, it automatically switches back to normal operation and the display displays the selected channel.

## Indications and displays on the receiver

### RF signal indication

The RF signal indication ④ (tower with radio waves) on the LC display provides information on the RF signal reception:

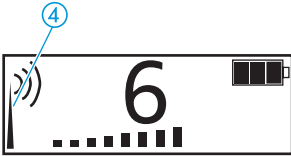

#### Tower with radio waves:

An RF signal is being received on the selected channel.

#### Tower without radio waves:

No RF signal is being received on the selected channel or the received signal level is too low.

#### No tower, no radio waves

HDE 2020 D only: The receiver is in standby mode. You can, however, change the settings on the receiver.



### Signal strength

The received signal strength may be reduced due to body absorption of the RF signal.

### Charge status LED

During charging,

- the LED ④ of the EK 2020 D or
- the LED ② of the HDE 2020 D

provides information on the charge status of the receiver's built-in rechargeable battery.

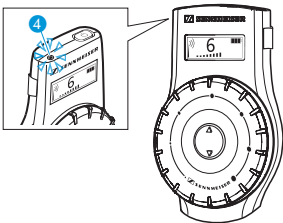

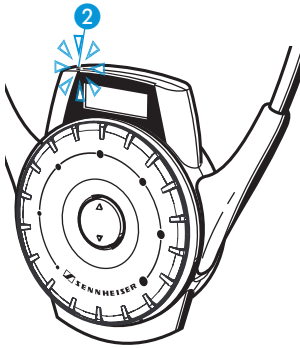

### LED lights up red:

The built-in rechargeable battery is being charged.

### LED lights up green:

The built-in rechargeable battery is fully charged. The receiver is now ready for operation.

### LED slowly flashes red:

The temperature of the built-in rechargeable battery is outside the permissible range (3°C to 40°C). The charging process is interrupted until the temperature is again within the admissible range.

### LED lights up yellow/orange:

The built-in rechargeable battery is defective. Please contact your Sennheiser partner.

### Volume display



The volume display ③ provides information on the current volume level.

### Channel display

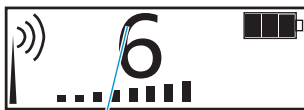

The channel display ① provides information on the currently selected channel.

### Battery status display



The 4-step battery status display ② provides information on the capacity of the receiver's built-in rechargeable battery.

Shortly before the rechargeable battery is completely discharged, the display backlighting flashes, indicating that the receiver will soon switch off automatically.

## Indications and displays on the charging case

### Operation indication

The LED **POWER** 6 lights up as long as the mains supply is switched on.

### Temperature indication

The LED **TEMP ERROR** 7 lights up if the temperature in the charging case gets too high and will remain on until the temperature drops to a safe level. All charging processes are interrupted until the temperature drops to a safe level.

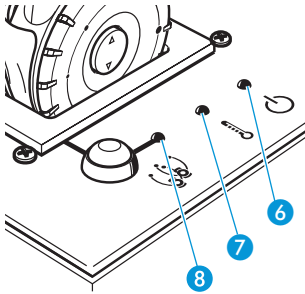

### LED indication for “automatic copying” function

The LED **COPY AVAILABLE** 8 lights up green when the “automatic copying” function is available. This happens

- when a switched-on receiver is placed into the charging compartment with channel copy function (master) 10
- and at least one receiver is placed into one of the other receiver charging compartments (slaves, light blue in the diagram) 5.

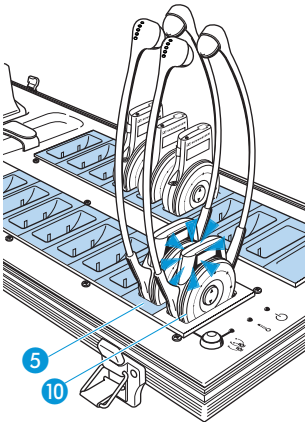

The LED **COPY AVAILABLE** 8 goes off when the “automatic copying” function is not available. This happens

- when the receiver in the charging compartment with channel copy function (master) 10 is switched off,
- or when the receiver is removed from the charging compartment with channel copy function (master) 10,
- or when all 19 charging compartments (slaves) 5 are empty.

### LED indication for charging compartments for BA 2015 accupack/bodypack transmitter

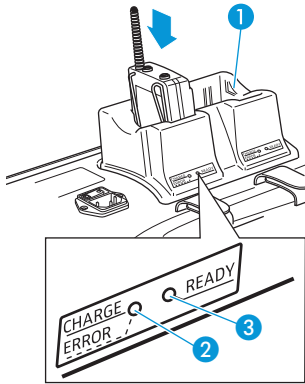

Each charging compartment for accupack/bodypack transmitter ① has an LED CHARGE/ERROR ② and an LED READY ③ which indicate the following operating states:

#### No LED lit:

- The charging compartment for accupack/bodypack transmitter ① is ready for operation but empty.

OR:

- A bodypack transmitter without accupack has been placed into the charging compartment.

#### Red LED CHARGE/ERROR ② lit:

The accupack is being charged. A red flashing LED for error indication, as with the L 2015 charger, is not available on the EZL 2020-20 L charging case.

#### Green LED READY ③ lit:

The accupack is fully charged and the charging case has switched to trickle charging.

#### Green LED READY ③ lights up briefly and then goes off:

The bodypack transmitter is powered by standard batteries which cannot be recharged.

## The functions of the operating controls of the bodypack transmitter/radio microphone

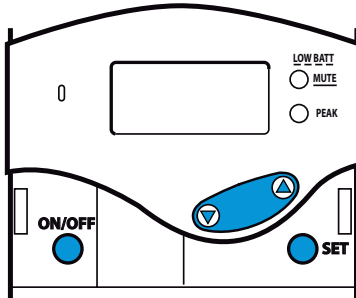

Bodypack transmitter

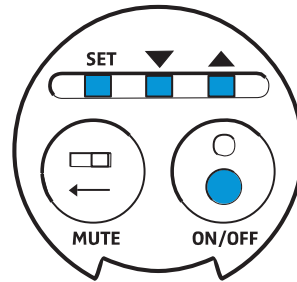



Radio microphone

| Operating control | Mode*               | Function   |
|-------------------|---------------------|--|
| ON/OFF button     | Switched off        | Pressing the button: Switches the bodypack transmitter/radio microphone on                                 |
|                   | Switched on         | Pressing the button for approx. 3 seconds: Switches the bodypack transmitter/radio microphone off          |
|                   | Selection mode      | Cancels the selection and returns to the standard display (ESC function)                                   |
|                   | Setting mode        | Cancels the entry and returns to the selection mode without storing the changes made (ESC function)        |
| SET button        | Standard display    | Changes to the selection mode  |
|                   | Selection mode      | Changes to the setting mode of the selected menu   |
|                   | Setting mode        | Stores the setting and returns to the selection mode ("STORED" is displayed briefly)                       |
|                   | Lock mode activated | Changes directly to the "LOCK" menu item where you can deactivate the lock mode                            |
| ▲/▼ buttons       | Standard display    | No function  |
|                   | Selection mode      | Changes to the previous menu item (▲) or changes to the next menu item (▼)                                 |
|                   | Setting mode        | Increases (▲) or reduces (▼) the setting of the selected menu item or switches the menu item (ON) or (OFF) |

\* For information on the menu areas "standard display", "selection mode" and "setting mode", please see "Overview of the bodypack transmitter's operating menu" on page 49.

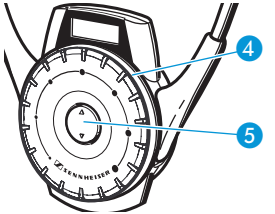
## The functions of the operating controls of the receivers

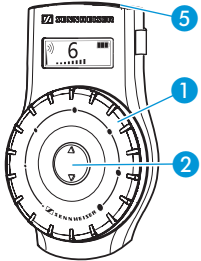
| HDE 2020 D  | Operating control                 | Function   |
|---|-----------------------------------|--|
|  | Volume control 4                  | Turning the volume control:<br>Changes the volume                            |
|   | Channel selection button<br>▲/▼ 5 | Changes to the next channel (▲)<br>or changes to the previous<br>channel (▼) |
|   | Earbows                           | Pulling the earbows apart:<br>Switches the stethoset receiver on             |

| EK 2020 D   | Operating control   | Function   |
|---|---|--|
|  | Volume control 1  | Turning the volume control:<br>Changes the volume                            |
|   | Channel selection<br>button ▲/▼ 2   | Changes to the next channel (▲)<br>or changes to the previous<br>channel (▼) |
|   | ON/OFF button 5  | Switches the receiver on/off   |

## The functions of the operating controls of the charging case

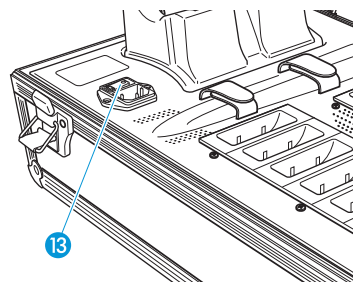
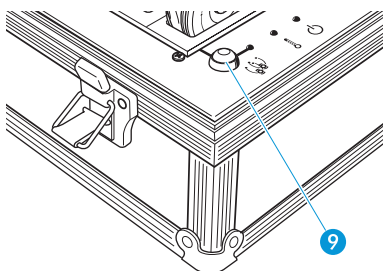

| Operating control | Function                                       |
|-------------------|--|
| COPY button 9     | Starts the channel copy function (see page 37) |
| Mains switch 13   | Switches the charging case on/off              |

# Putting the components into operation

## Setting up the charging case

### Note:

The charging case as well as the accupacks and the receivers' built-in rechargeable batteries will get hot during charging. Please ensure the following so that the generated heat can dissipate:

- The air vents **11** of the charging case must not be covered or blocked.
- The charging case must be kept away from heat sources and must never be exposed to direct sunlight.
- During charging, do not put the case cover on the charging case.

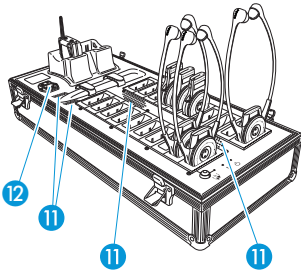

The charging case has four plastic feet to ensure that it cannot slip on the surface on which it is placed.

**CAUTION!** Some furniture surfaces have been treated with varnish, polish or synthetics which might cause stains when they come into contact with other synthetics. Despite a thorough testing of the synthetics used by us, we cannot rule out the possibility of staining.



- ▶ Place the charging case on a flat, even surface.
- ▶ Connect the supplied mains cable to the IEC mains socket **12** on the charging case.
- ▶ Connect the mains cable to a wall socket.

### Note:

The case cover can be used as a stand for the charging case (see diagram on the left).

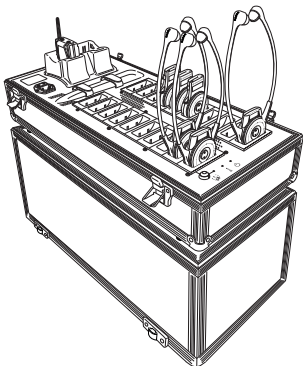

### Inserting and replacing the batteries/accupack of the radio microphone

For powering the radio microphone, you can either use the rechargeable BA 2015 accupack **5** or two 1.5 V AA size batteries. NB: Do not use any other rechargeable batteries!

- ▶ Unscrew the display section **4** from the radio microphone's body **2** by turning it counterclockwise.

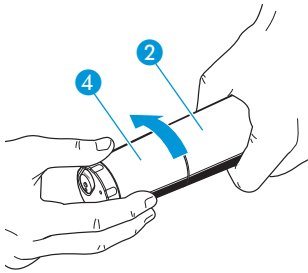

- ▶ Slide back the the display section **4** as far as it will go.

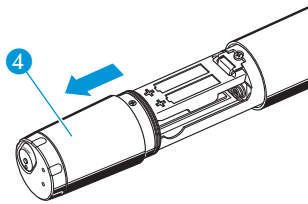

- ▶ Open the battery compartment cover **13**.

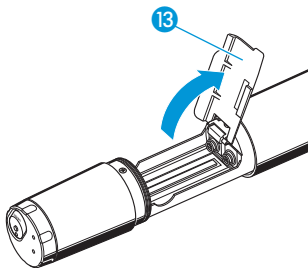

- ▶ Insert the batteries or the BA 2015 accupack as shown on the battery compartment cover. Observe correct polarity when inserting the batteries/accupack.

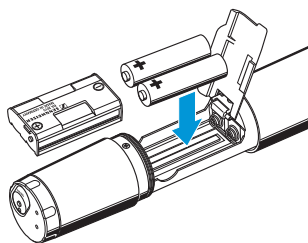

- ▶ Close the battery compartment cover **13**.
- ▶ Push the battery compartment into the radio microphone's body.
- ▶ Screw the display section tight.

**Note:**

Always charge the accupack in the charging compartment ① of the charging case (see "Charging the BA 2015 accupack" on page 33).

### Inserting and replacing the batteries/accupack of the bodypack transmitter

For powering the bodypack transmitter, you can either use the rechargeable BA 2015 accupack ⑤ or two 1.5 V AA size batteries. NB: Do not use any other rechargeable batteries!

- ▶ Push the two battery compartment catches ⑭ and open the battery compartment cover ④.
- ▶ Insert the BA 2015 accupack ⑤ or the batteries as shown in the diagram on the left. Please observe correct polarity when inserting the accupack/batteries.
- ▶ Close the battery compartment cover ④.

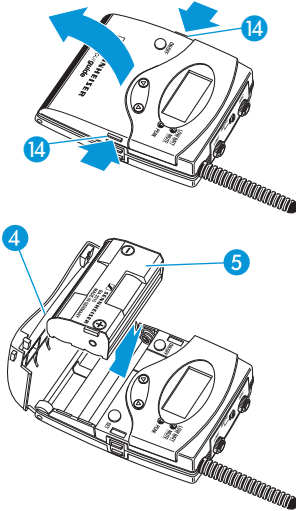

### Connecting a microphone to the bodypack transmitter

**Note:**

Suitable Sennheiser microphones are listed on page 8.

- ▶ Connect the microphone to the microphone input ③ of the bodypack transmitter.
- ▶ Lock the plug by screwing down the coupling ring.
- ▶ Adjust the sensitivity of the microphone input as described on page 42.

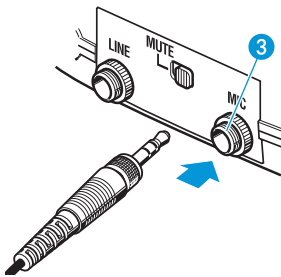

### Connecting external audio sources

You can connect an external audio source such as a CD player, MP3 player, tape player, etc. to the bodypack transmitter. (Please note that you cannot connect a second microphone.) Both signals – the microphone input signal and the line input signal – are mixed together equally in the transmitter.

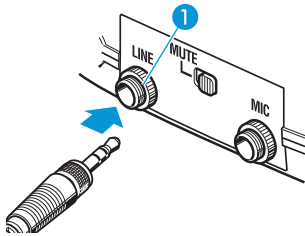

- ▶ Connect the line output of the external audio source to the line input ① of the bodypack transmitter.
- ▶ Lock the plug by screwing down the coupling ring.
- ▶ Switch the line input on as described on page 40.
- ▶ Adjust the sensitivity of the line input as described on page 41.

Mic input (dynamic):

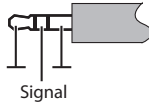

Mic input (Electret):

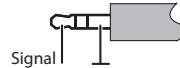

LINE input:

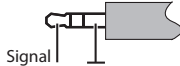

LINE input:



LINE input:

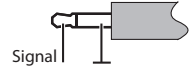

### Attaching the bodypack transmitter to clothing

The bodypack transmitter is attached to clothing (e.g. belt, waistband) with the supplied belt clip ⑯.

The clip is detachable so that you can also attach the bodypack transmitter with the antenna pointing downwards. To do so, withdraw the clip ⑯ from its fixing points and attach it the other way round.

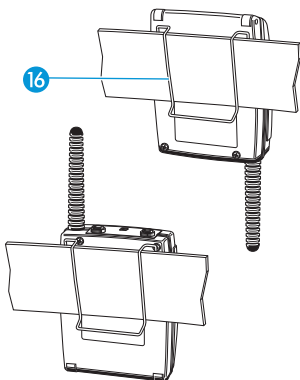

# Using the components

## Switching the devices on/off

### Notes:

- Remove the batteries or the accupack when the bodypack transmitter/radio microphone will not be used for extended periods of time.
- If no transmission is to take place, switch the transmitters off in order to free up the frequency range for other applications.

### Switching the bodypack transmitter on/off

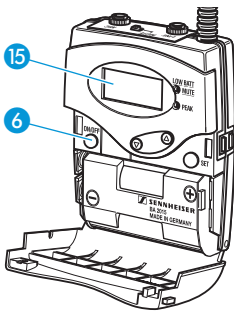

To switch the bodypack transmitter on:

- ▶ Briefly press the ON/OFF button 6. The display 15 indicates the device name and then switches to the standard display.

To switch the bodypack transmitter off:

- ▶ Press and hold the ON/OFF button 6 until "OFF" appears on the display.

### Switching the radio microphone on/off

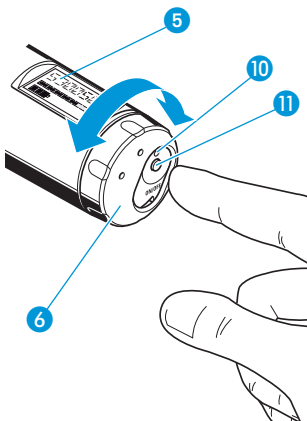

To switch the radio microphone on:

- ▶ Turn the protective cap 6 so that the ON/OFF button 11 becomes accessible.
- ▶ Press the ON/OFF button 11 to switch the radio microphone on. The red LED 10 lights up. The display 5 indicates the device name and then switches to the standard display.

To switch the radio microphone off:

- ▶ Press and hold the ON/OFF button 11 until "OFF" appears on the display. The display 5 and the red LED 10 go off.

### Automatically switching the HDE 2020 D on/off

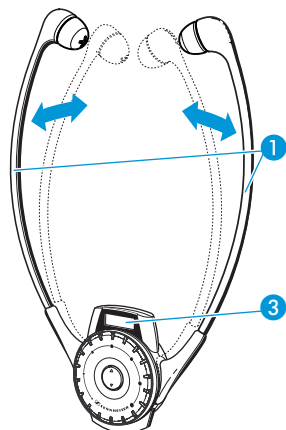

The receiver automatically switches on when you pull the earbows ① apart. The display ③ switches on.

When you release the earbows, the receiver switches to standby mode (audio deactivated) and then switches off after 2 minutes.

### Switching the EK 2020 D on/off

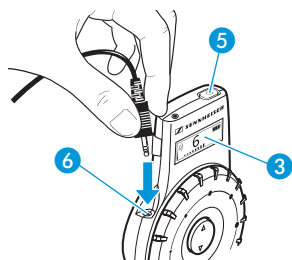

You can connect an induction loop or any pair of headphones with a 3.5 mm mono or stereo jack plug to the headphone socket ⑥ of the EK 2020 D. The headphone impedance must be 32 Ω or higher.

- ▶ Connect the 3.5 mm jack plug of your headphones to the headphone socket of the EK 2020 D.

To switch the receiver on:

- ▶ Briefly press the ON/OFF button ⑤ . The display ③ switches on.

To switch the receiver off:

- ▶ Press the ON/OFF button ⑤  for 3 seconds.



When you unplug the headphones from the receiver or switch off the transmitter, the receiver automatically switches off after 5 minutes.

### Switching the charging case on/off

To switch the charging case on:

- ▶ Set the mains switch ⑬ to the position "I". The LED POWER ⑥  lights up.

To switch the charging case off:

- ▶ Set the mains switch ⑬ to the position "0". The LED POWER ⑥  goes off.

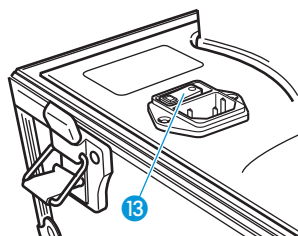

**Note:**

When not using the charging case for extended periods of time, switch it off and disconnect it from the mains by pulling out the mains connector from the wall socket.

## Adjusting the volume

### Adjusting the volume on the receiver

---

#### **CAUTION!** Danger of hearing damage!



Listening at high volume levels for long periods can lead to permanent hearing defects.

▶ Adjust the volume to a low level before using the receiver.

---



▶ Use

- the volume control **4** of the HDE 2020 D or
- the volume control **1** of the EK 2020 D

to adjust the volume so that you can hear the speaker's voice loud and clear.

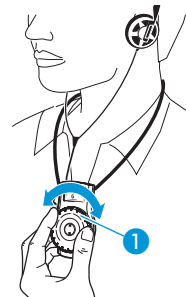
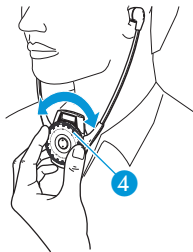
**Note:**

The volume control **4** or **1** has no end stop, i. e. you can turn it endlessly to the left or right.

## Charging the rechargeable batteries

### CAUTION!



- Only use the charging case for charging the SK 2020 D bodypack transmitter, the HDE 2020 D and EK 2020 D receivers and the BA 2015 accupack.
- Never try to charge other rechargeable batteries or non-rechargeable batteries!

### Charging the accupack in the bodypack transmitter

To charge the bodypack transmitter in the EZL 2020-20 L charging case:

- ▶ Place the transmitter with the accupack inserted into the charging compartment for accupack/bodypack transmitter ① as shown in the diagram on the left.

When placed into a charging compartment, the bodypack transmitter automatically switches off. The red LED CHARGE/ERROR ② of the charging compartment lights up.

After the accupack has been fully charged, the green LED READY ③ lights up.

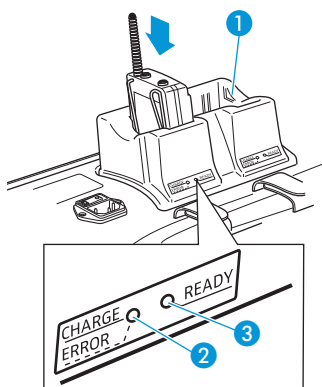

### Notes:

- Charging a completely discharged accupack takes approx. 3½ hours at room temperature.
- Alternatively, you can remove the accupack from the bodypack transmitter and insert it into the charging compartment for accupack/bodypack transmitter ① as described in the following section.
- The charging case has no error indication like the one on the L 2015 charger (“red flashing LED”).

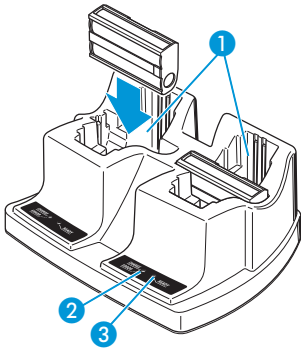

## Charging the BA 2015 accupack

To charge the accupack of the radio microphone or bodypack transmitter:

- ▶ Remove the accupack as described on page 26 or page 27.
- ▶ Place the accupack into the charging compartment for accupack/bodypack transmitter ① as shown in the diagram on the left.

The red LED CHARGE/ERROR ② of the charging compartment lights up.

After the accupack has been fully charged, the green LED READY ③ lights up.

### Notes:

- Charging a completely discharged accupack takes approx. 3½ hours at room temperature. It is normal for the accupacks to get hot during charging.
- However, the charging process may take longer if:
  - the accupack is deep-discharged and first has to be reconditioned by a deep discharge recovery charge,
  - the ambient temperature is close to or over 40°C, since, in order to protect the accupack, the charging process will be interrupted until the temperature has dropped to a safe level.
- For safety reasons, each charging process will be interrupted after 4 hours.
- When not using the BA 2015 accupack for extended periods of time, charge it about every three to six months.

## Charging the receivers' built-in rechargeable batteries

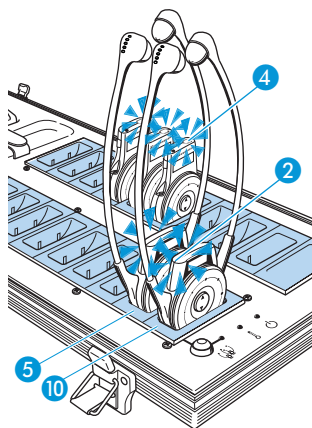

► Place the receiver into one of the charging compartments for receivers **5**/**10** (light blue in the diagram).

- The LED **2** of the HDE 2020 D or
  - the LED **4** of the EK 2020 D
- lights up (see table).

| LED colour     | Meaning   |
|----------------|---|
| red            | The built-in rechargeable battery is being charged.   |
| green          | The built-in rechargeable battery is fully charged.   |
| red (flashing) | The temperature of the built-in rechargeable battery is over 40°C or below 3°C.                                     |
| yellow/orange  | The built-in rechargeable battery is defective. Interrupt the charging process and contact your Sennheiser Service. |

### Notes:

- Charging a completely discharged rechargeable battery of the HDE 2020 D takes approx. 2½ hours at room temperature.
- Charging a completely discharged rechargeable battery of the EK 2020 D takes approx. 5 hours at room temperature.
- However, the charging process may take longer if:
  - the rechargeable battery is deep discharged and first has to be reconditioned by a deep discharge recovery charge,
  - the temperature of the built-in rechargeable battery is over 40°C or below 3°C, since, in order to protect the rechargeable battery, the charging process will be interrupted until the temperature is again within the permissible range (the LED **2** of the HDE 2020 D or the LED **4** of the EK 2020 D flashes red).

- An additional temperature protection prevents overheating inside the charging case. If the temperature inside the charging case exceeds safety limits, the charging process will be interrupted and will only be restarted when the charging case has cooled down.
- When not using the receivers for extended periods of time, charge them about every six months in order to prevent deep discharge damage to the rechargeable batteries.

## Setting a channel

To set the complete system to a certain channel, proceed as follows:

1. Set the bodypack transmitter/radio microphone to the desired channel (see next section).
2. Set one of the receivers to the same channel (see "Setting the channel on the receiver" on page 37).
3. Automatically set all other receivers to the same channel using the channel copy function (see "Setting the receiver channel(s) using the channel copy function" on page 37).

### Setting the channel on the bodypack transmitter/ radio microphone

To set the bodypack transmitter or the radio microphone to the desired channel, use the operating menu of the device. An overview of the operating menus is given from page 49 onwards.

- ▶ Make sure that the lock mode is deactivated (see “Activating/deactivating the lock mode” on page 45).

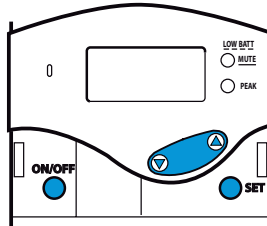

Bodypack transmitter

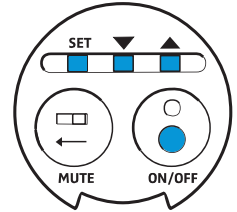

Radio microphone

- ▶ Press the **SET** button.  
The operating menu appears and the first menu item “**CHAN**” flashes on the display.
- ▶ Press the **SET** button.  
The current channel flashes on the display.
- ▶ Press **▲/▼** to change the channel.  
If you press **▲**, the display jumps to the next channel; if you press **▼**, the display jumps to the previous channel.  
By pressing and holding the **▲/▼** buttons, the display cycles continuously (repeat function).
- ▶ Press the **SET** button to permanently store the selected channel.  
“**STORED**” briefly appears on the display. The bodypack transmitter or the radio microphone now transmits on the selected channel. The last menu item selected is shown on the display.

To exit the operating menu:

- ▶ Use **▲/▼** to select the “**EXIT**” menu item and press the **SET** button.  
The standard display is shown.

Or:

- ▶ Press and hold the **ON/OFF** button until the standard display is shown.

## Setting the channel on the receiver

In order for the receiver to receive the signal from the bodypack transmitter or radio microphone, it has to be set to the **same channel**.

To manually set the receiver channel:

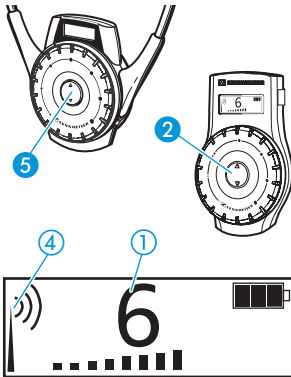

▶ Press

- the channel selection button ▲/▼ 5 of the HDE 2020 D or
- the channel selection button ▲/▼ 2 of the EK 2020 D.

▶ The channel changes. The selected channel is shown on the channel display 1.

If the bodypack transmitter or radio microphone is transmitting on this channel, the RF signal indication 4 indicates the field strength of the received RF signal.

## Setting the receiver channel(s) using the channel copy function

The channel copy function lets you simultaneously set a maximum of 19 receivers in the charging case to the same channel. This is achieved by copying the current channel of the receiver placed into the charging compartment with channel copy function (master) 10 to all other receivers in the charging case.

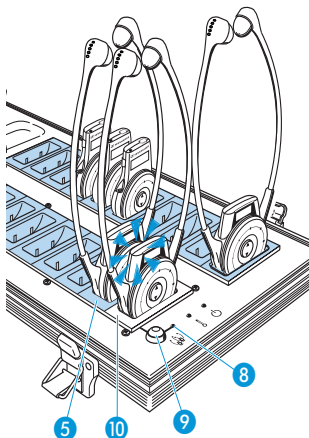

▶ Place all receivers which are to be set to the same channel into the charging compartments for receivers (slaves, light blue in the diagram) 5.

▶ Switch on the receiver whose channel you want to copy.

▶ Place this receiver into the charging compartment with channel copy function (master) 10.

The LED COPY AVAILABLE 8 lights up green as long as the channel copy function is available.

▶ Press the COPY button 9 to start the channel copy function.

The displays of all receivers which are successfully set to the same channel light up.

**Notes:**

- If the receivers' built-in rechargeable batteries are not discharged, you can use the channel copy function even when the charging case is not connected to the mains.
- If you do not press the **COPY** button **9**, the receiver placed into the charging compartment with channel copy function (master) **10** will automatically switch off after approx. 2 minutes.

**Using several Tourguide systems simultaneously**

If you are using the Tourguide System 2020 D to run several guided tours simultaneously, the systems could interfere with one another. To prevent this happening, you have to set the systems to different channels (a system consists of one bodypack transmitter or one radio microphone and any number of receivers).

## Muting the devices

### Muting the bodypack transmitter

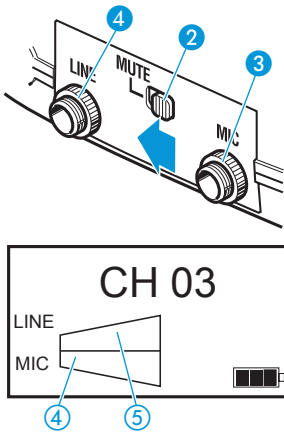

- ▶ Slide the **MUTE** switch (2) to the left, to “MUTE”.
- ▶ The red LED **LOW BATT/MUTE** (7) lights up permanently. The **MIC** level display (4) no longer shows any deflection. The bodypack transmitter’s microphone input is muted.

#### Note:

The muting function (MUTE) mutes the microphone input (3) but not the line input (4). This function enables a pre-recorded track to be played through the line input without being disturbed by the tour guide’s microphone. When the track has finished, the guide can un-mute the microphone and continue talking.

To deactivate the muting function:

- ▶ Slide the **MUTE** switch (2) back to the right. The red LED **LOW BATT/MUTE** (7) goes off. The **MIC** level display (4) and the **LINE** level display (5) indicate the current levels.

### Muting the radio microphone

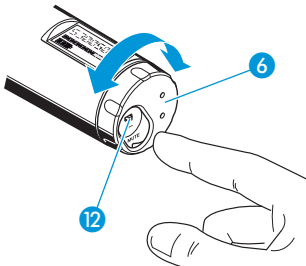

- ▶ Turn the protective cap (6) so that the **MUTE** switch (12) becomes accessible.
- ▶ Slide the **MUTE** switch (12) in the direction of the arrow. “MUTE” appears on the display of the radio microphone. After 5 minutes, “CH OFF” appears on the display (see “Display of the energy saving mode” on page 16).

To deactivate the muting function:

- ▶ Slide the **MUTE** switch (12) back in order to transmit the audio signal again.

## Special bodypack transmitter/radio microphone settings

The following special settings can only be made via the bodypack transmitter's/radio microphone's operating menu. An overview of this operating menu is given from page 49 onwards.

### Switching the bodypack transmitter's line input on/off

You can connect an audio source such as a CD player, MP3 player, etc. to the bodypack transmitter's line input. If you have connected an audio source, you then have to switch on the line input as follows:

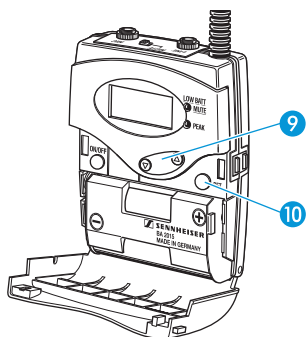

- ▶ Press the **SET** button **10**.  
The operating menu appears and the first menu item "CHAN" flashes on the display.
- ▶ Repeatedly press the **▲/▼** rocker button **9** in the **▼** direction until "LINE" flashes on the display.
- ▶ Press the **SET** button **10**.  
If the line input is switched off, "LINE.OFF" flashes on the display; if the line input is switched on, "LINE.ON" flashes on the display.
- ▶ Press the **▲/▼** rocker button **9** to change the setting.
- ▶ Press the **SET** button **10** to permanently store the setting.  
"STORED" briefly appears on the display.
- ▶ Adjust the sensitivity of the line input to match the connected audio source as described in the following section.

## Changing the sensitivity of the bodypack transmitter's line input

To adjust the sensitivity of the line input to match the connected audio source:

- ▶ Make sure that the line input is switched on (see previous section).
- ▶ Connect the external audio source, switch it on and start playback.
- ▶ Press the **SET** button **10**.  
The operating menu appears and the first menu item "CHAN" flashes on the display.
- ▶ Repeatedly press the **▲/▼** rocker button **9** until "SENSIT" flashes on the display and the **LINE** level display **5** appears.
- ▶ Press the **SET** button **10**.  
The current input sensitivity and the **LINE** level display **5** appear on the display.
- ▶ Press the **▲/▼** rocker button **9** to change the input sensitivity so that the **LINE** level display **5** shows full deflection during the loudest passages, but the yellow LED **PEAK** **8** does not light up permanently.
- ▶ Press the **SET** button **10** to permanently store the setting.  
"STORED" briefly appears on the display, indicating that the sensitivity of the line input has been stored.

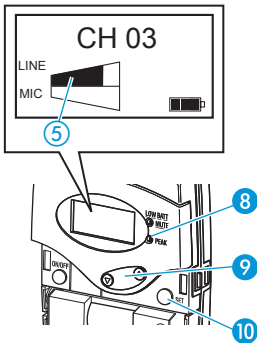

## Changing the sensitivity of the bodypack transmitter's microphone input

To adjust the sensitivity of the microphone input to match the connected microphone:

- ▶ Connect the microphone, position it correctly (refer to the microphone's instruction manual) and speak into the microphone as usual.
- ▶ Press the **SET** button **10**.  
The operating menu appears and the first menu item "CHAN" flashes on the display.
- ▶ Repeatedly press the **▲/▼** rocker button **9** until "SENSIT" flashes on the display and the **MIC** level display **4** appears.
- ▶ Press the **SET** button **10**.  
The current input sensitivity and the **MIC** level display **4** appear on the display.
- ▶ Press the **▲/▼** rocker button **9** to change the input sensitivity so that the **MIC** level display **4** shows full deflection during the loudest passages, but the yellow LED **PEAK** **8** does not light up permanently.
- ▶ Press the **SET** button **10** to permanently store the setting.  
"STORED" briefly appears on the display, indicating that the sensitivity of the microphone input has been stored.

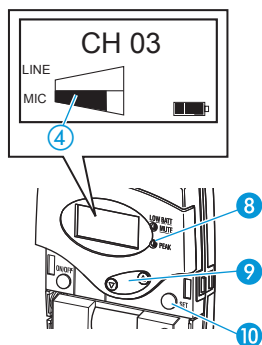

## Adjusting the radio microphone's input sensitivity

The input sensitivity is adjusted too high when close talking distances or speakers with loud voices cause overmodulation in the transmission link. When the audio input level is excessively high, the audio level display (AF) ④ shows full deflection.

If, on the other hand, the input sensitivity is adjusted too low, the transmission link will be undermodulated, which would result in a signal with high background noise.

The input sensitivity is **correctly** adjusted when the audio level display (AF) only shows full deflection only during the loudest passages.

To adjust the sensitivity of the radio microphone:

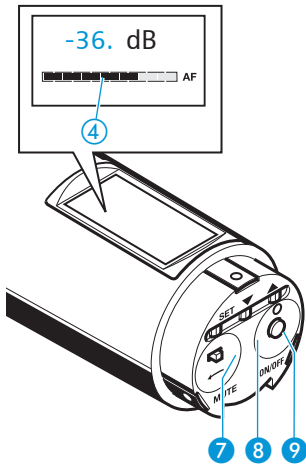

- ▶ Press the **SET** button ⑦.

The operating menu appears and the first menu item "CHAN" flashes on the display.

- ▶ Repeatedly press the ▲/▼ buttons ⑧/⑨ until "SENSIT" flashes on the display and the audio level display ④ appears.

- ▶ Press the **SET** button ⑦.

The current input sensitivity and the audio level display ④ appear on the display.

- ▶ Press the ▲/▼ buttons ⑧/⑨ to change the setting so that the audio level ④ shows full deflection only during the loudest passages.

- ▶ Press the **SET** button ⑦ to permanently store the setting.

"STORED" briefly appears on the display, indicating that the input sensitivity of the radio microphone has been stored.

The following figures are a guide to the best settings:

- Presentation: -24 to -12 dB
- Interview: -12 to 0 dB

## Displaying the transmission frequency of the bodypack transmitter/radio microphone

To display the transmission frequency assigned to the current channel:

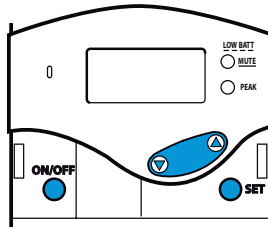

Bodypack transmitter

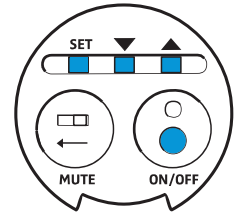

Radio microphone

- ▶ Press the **SET** button.  
The operating menu appears and the first menu item "CHAN" flashes on the display.
- ▶ Repeatedly press ▲/▼ until "FREQ" flashes on the display.
- ▶ Press the **SET** button.  
The transmission frequency assigned to the current channel appears on the display. You cannot change this transmission frequency.
- ▶ Press the **ON/OFF** button or the **SET** button to return to the operating menu.

## Loading the factory-preset default settings

To load the factory-preset default settings of the bodypack transmitter/radio microphone:

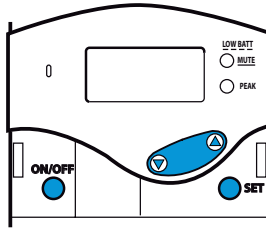

Bodypack transmitter

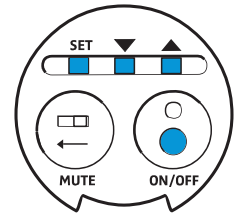

Radio microphone

- ▶ Press the **SET** button.  
The operating menu appears and the first menu item "CHAN" flashes on the display.
- ▶ Repeatedly press ▲/▼ until "RESET" flashes on the display.
- ▶ Press the **SET** button.  
"RST.OK" flashes on the display.
- ▶ Press the **SET** button to load the factory-preset default settings.  
"DONE" briefly appears on the display. The bodypack transmitter/radio microphone is reset to the following factory-preset default settings:
  - Channel: 1
  - Line input: switched off  
(bodypack transmitter only)
  - Input sensitivity:
    - Line input: -24 dB  
(bodypack transmitter only)
    - Microphone input: -12 dB
  - Lock mode: deactivated
  - Infra-red service interface: deactivated

## Activating/deactivating the lock mode

The lock mode prevents the bodypack transmitter/radio microphone from being accidentally programmed or switched off during operation.

To **activate** the lock mode:

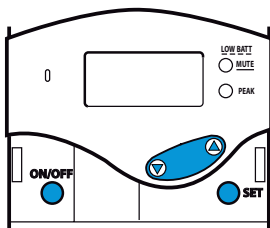

Bodypack transmitter

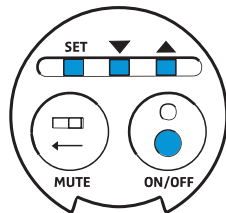

Radio microphone



- ▶ Press the **SET** button.  
The operating menu appears. The first menu item "CHAN" flashes.
- ▶ Repeatedly press ▲/▼ until "LOCK" appears on the display.
- ▶ Press the **SET** button.  
"LOC.OFF" flashes on the display.
- ▶ Press ▲/▼.  
"LOC.ON" flashes on the display.
- ▶ Press the **SET** button to activate the lock mode.  
"STORED" briefly appears on the display, indicating that the lock mode has been activated. The lock mode icon ② is displayed on the standard display.

To **deactivate** the lock mode:

- ▶ Press the **SET** button.  
"LOC.ON" flashes on the display.
- ▶ Press ▲/▼.  
"LOC.OFF" flashes on the display.
- ▶ Press the **SET** button to deactivate the lock mode.  
"STORED" briefly appears on the display, indicating that the lock mode has been deactivated. The lock mode icon ② is no longer displayed on the standard display.

## Displaying the version number of the bodypack transmitter/radio microphone

To display the version number of the operating system installed:

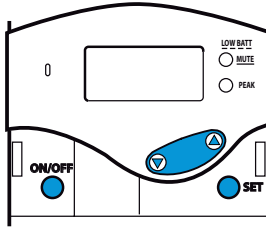

Bodypack transmitter

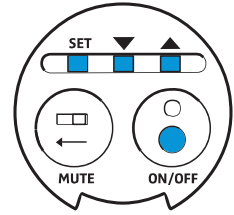

Radio microphone

- ▶ Press the **SET** button.  
The operating menu appears and the first menu item "CHAN" flashes on the display.
- ▶ Repeatedly press ▲/▼ until "SERVIC" flashes on the display.
- ▶ Press the **SET** button.  
The version number is displayed.

V 1.001

## The operating menu of the bodypack transmitter/radio microphone

The bodypack transmitter's/radio microphone's operating menu contains the following menu items:

| Menu item      | Meaning   |
|----------------|---|
| CHAN           | Selects a channel (see page 35)                               |
| LINE*          | Switches the line input on/off (see page 40)                  |
| SENSIT (LINE)* | Changes the sensitivity of the line input (see page 41)       |
| SENSIT (MIC)   | Changes the sensitivity of the microphone input (see page 42) |
| FREQ           | Displays the frequency of the current channel (see page 44)   |
| RESET          | Loads the factory-preset default settings (see page 45)       |
| LOCK           | Activates/deactivates the lock mode (see page 45)             |
| SERVIC         | Displays the version number (see page 47)                     |
| EXIT           | Exits the operating menu                                      |

\*) only available with bodypack transmitter

## Overview of the bodypack transmitter's operating menu

Use the **ON/OFF** button to cancel your entry in all areas of the operating menu.

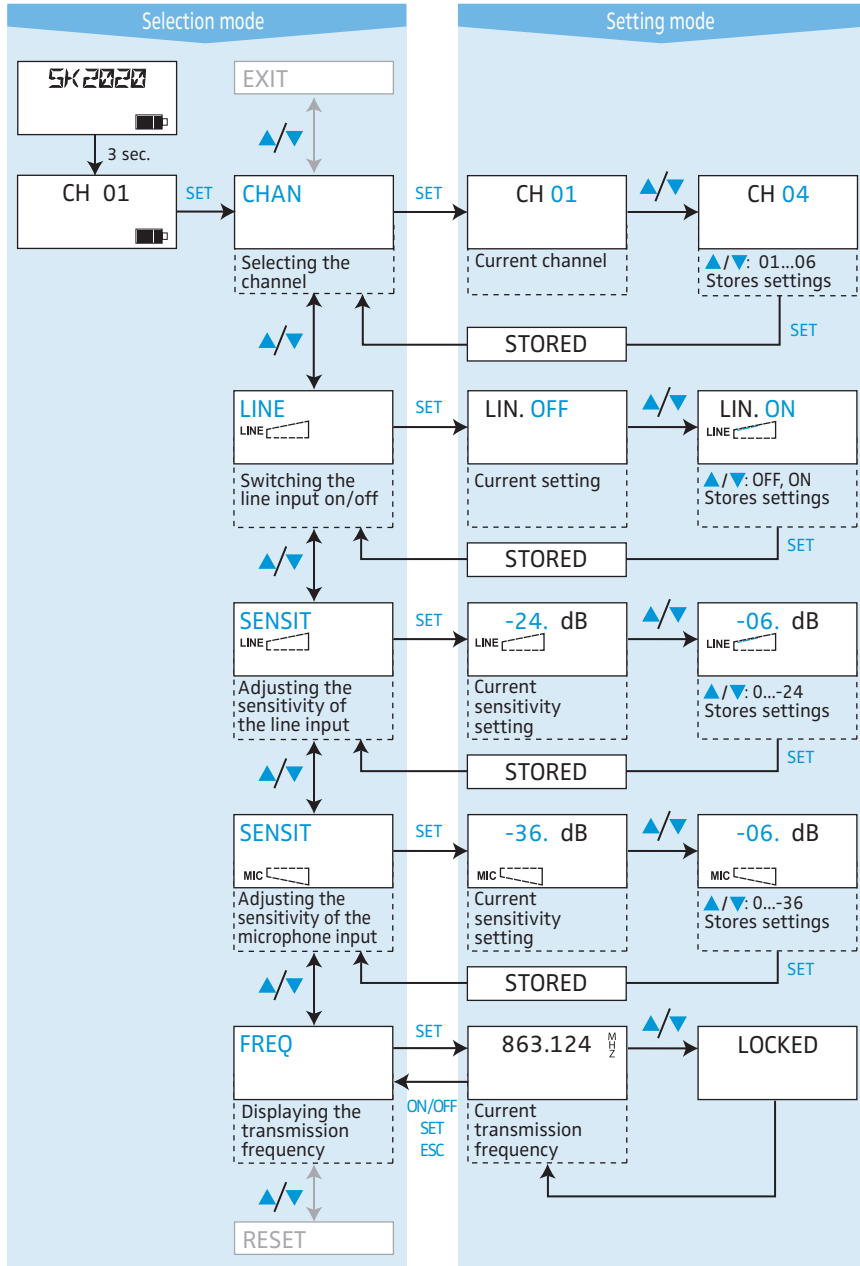

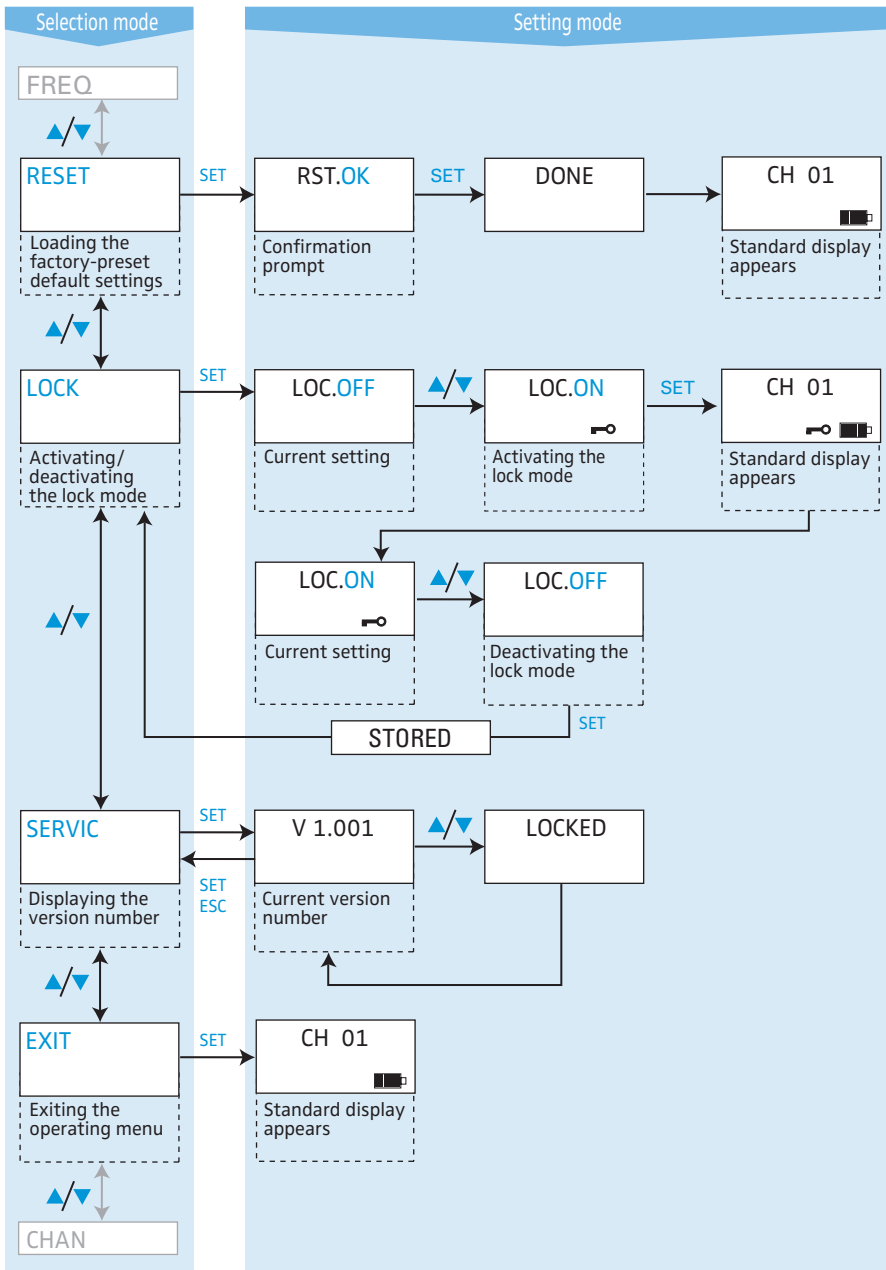

## Overview of the radio microphone's operating menu

Use the **ON/OFF** button to cancel your entry in all areas of the operating menu.

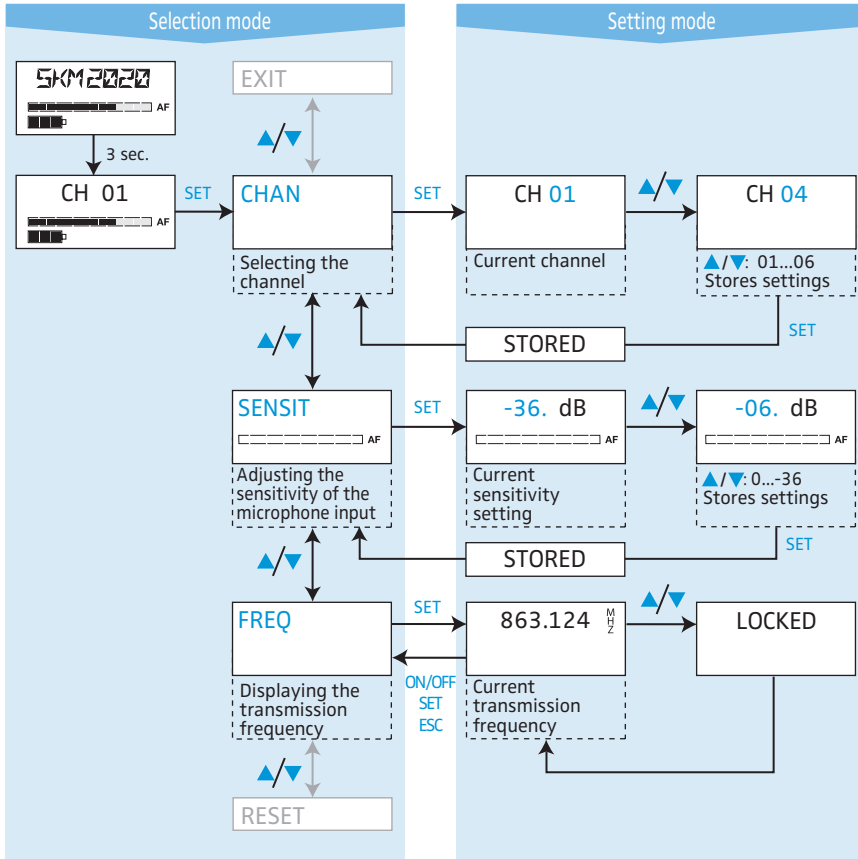

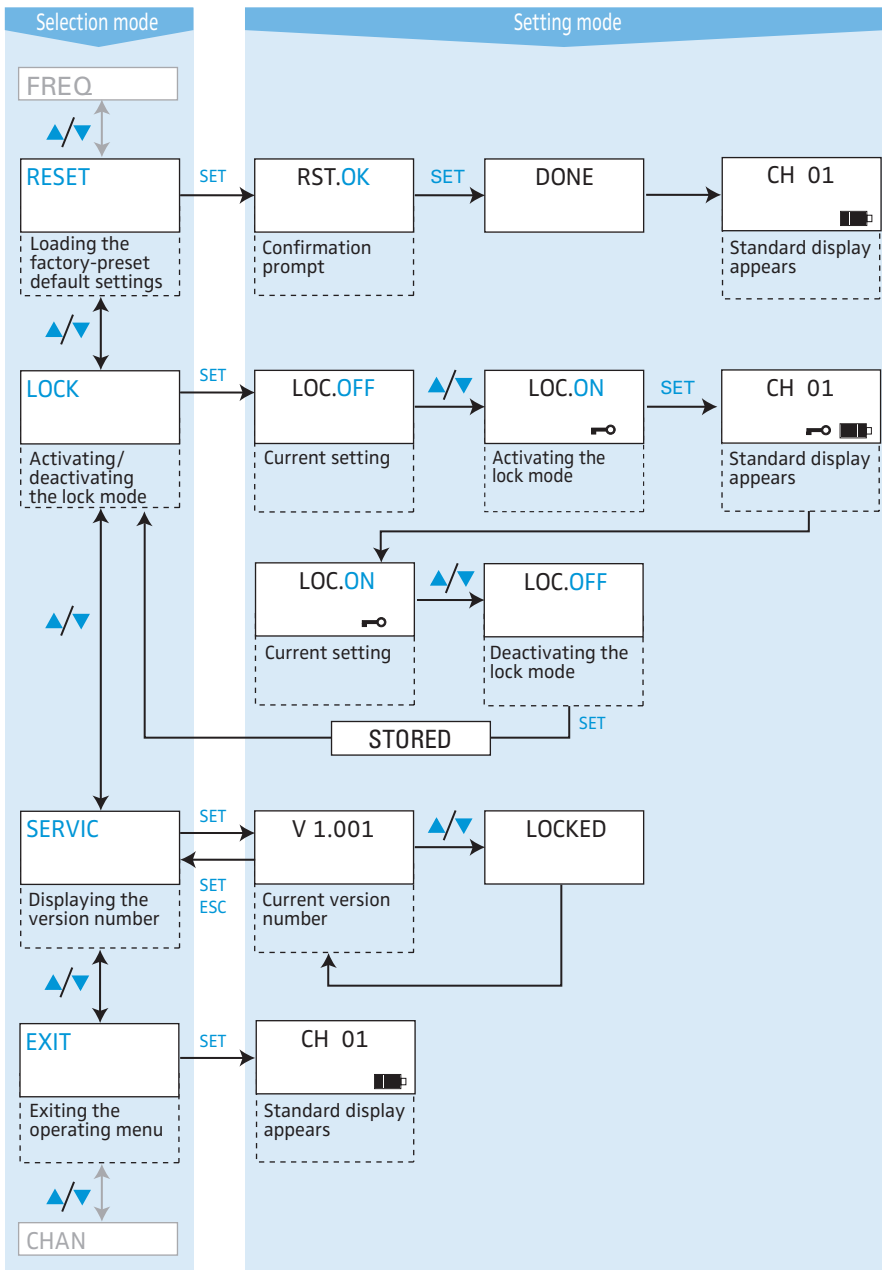

# Care and maintenance

---

**CAUTION!** Liquids can damage the electronics of the devices!

Liquids entering the housing of the devices can cause a short-circuit and damage the electronics.

▶ Keep all liquids away from the devices.

---

- ▶ Before cleaning, make sure that all devices are switched off and unplugged from the power supply.
- ▶ Use only a soft and dry cloth to clean the devices.

## Cleaning the earbuds of the HDE 2020 D



- ▶ Carefully pull the earbuds off the receiver.
- ▶ Clean the earbuds e. g. with warm, soapy water and rinse them well.
- ▶ Dry the earbuds before putting them back on the receiver.

### Note:

For reasons of hygiene, you should replace the earbuds from time to time (see "Accessories" on page 58).

## If a problem occurs...

In the following table, the term “transmitter” refers to both “bodypack transmitter” and “radio microphone”.

| Problem   | Possible cause   | Possible solution  |
|---|--|--|
| No operation indication on the transmitter  | Batteries are flat or accupack is flat                             | Replace the batteries or recharge the accupack (see page 33)                             |
| No radio waves on the receiver display  | No RF signal, transmitter and receiver are not on the same channel | Set transmitter and receiver to the same channel (see page 35)                           |
|   | No RF signal, transmitter is out of range                          | Reduce the distance between receiver and transmitter                                     |
|   | Transmitter is in energy saving mode (see page 16)                 | Check the signal source  |
| RF signal available, no audio signal, the red LED <b>LOW BATT/MUTE</b>  lights up on the transmitter | Transmitter is muted (MUTE)  | Deactivate the muting function (see page 39)   |
| Audio signal is distorted   | Transmitter sensitivity is adjusted too high                       | Change the sensitivity of the microphone input (see page 42) or line input (see page 41) |
| Operating time of the transmitter is drastically reduced  | Normal ageing or damage of BA 2015 accupack                        | Replace the BA 2015 accupack   |
| Operating time of the receivers is drastically reduced  | Normal ageing or damage of rechargeable batteries                  | Have the rechargeable batteries replaced by a Sennheiser Service Department              |
| Occasional drop outs in the audio signal  | Distance to the transmitter is too great                           | Reduce the distance to the transmitter   |
|   | Interference is being received from an external source             | Change the system to a different channel   |
|   | Interference is being received from a second transmitter           | Change the transmitters to different channels  |

If a problem occurs that is not listed in the above table or if the problem cannot be solved with the proposed solutions, please contact your local Sennheiser agent for assistance.

# Specifications

## SK 2020 D bodypack transmitter (Cat. No. 500548)

### SK 2020 D-US bodypack transmitter (Cat. No. 500549)

|                                      |   |
|--------------------------------------|---|
| Modulation                           | 2 FSK (46K0F1D)   |
| Frequency range                      | 863–865 MHz   |
| Frequency range (US)                 | 926–928 MHz   |
| Channels                             | 6   |
| RF output power                      | 10 mW   |
| RF output power (US)                 | max. 50 mV/m (distance 3 m)   |
| AF frequency response                | 100–7,000 Hz  |
| Max. input voltage at mic/line input | microphone: 650 mV <sub>rms</sub> (sensitivity –36 dB)<br>line: 2 V <sub>rms</sub> (sensitivity –24 dB) |
| Operating time                       | typ. 8 hrs  |
| Power supply                         | BA 2015 accupack, 2.4 V<br>or 2 AA size batteries, 1.5 V  |
| Ambient temperature                  | 0°C– 50°C   |
| Dimensions                           | approx. 82 x 64 x 24 mm   |
| Weight (incl. BA 2015 accupack)      | approx. 160 g   |

## SKM 2020 D radio microphone (Cat. No. 500894)

### SKM 2020 D-US radio microphone (Cat. No. 500895)

|                                 |  |
|---------------------------------|--|
| Modulation                      | 2 FSK (46K0F1D)  |
| Frequency range                 | 863–865 MHz  |
| Frequency range (US)            | 926–928 MHz  |
| Channels                        | 6  |
| RF output power                 | 10 mW  |
| RF output power (US)            | max. 50 mV/m (distance 3 m)                              |
| AF frequency response           | 100 – 7,000 Hz   |
| Operating time                  | typ. 8 hrs   |
| Power supply                    | BA 2015 accupack, 2.4 V<br>or 2 AA size batteries, 1.5 V |
| Ambient temperature             | 0°C–50°C   |
| Dimensions                      | approx. ∅ 50 mm x 225 mm                                 |
| Weight (incl. BA 2015 accupack) | 422 g  |

**HDE 2020 D stethoset receiver (Cat. No. 500543)**

**HDE 2020 D-US stethoset receiver (Cat. No. 500544)**

**EK 2020 D receiver (Cat. No. 502035)**

**EK 2020 D-US receiver (Cat. No. 502036)**

|                          | HDE 2020 D                                    | EK 2020 D                                      |
|--------------------------|---|--|
| Modulation               | 2 FSK   | 2 FSK  |
| Frequency range          | 863–865 MHz                                   | 863–865 MHz                                    |
| Frequency range (US)     | 926–928 MHz                                   | 926–928 MHz                                    |
| Channels                 | 6   | 6  |
| AF frequency response    | 100–7,000 Hz                                  | 100–7,000 Hz                                   |
| Headphone output power   | –   | max. 10 mW/ 32Ω                                |
| Min. headphone impedance | 32 Ω  | 32 Ω   |
| THD at 1 kHz             | < 1%  | < 1%   |
| Operating time           | typ. 8 hrs                                    | typ. 16 hrs                                    |
| Power supply             | Lithium-Polymer rechargeable battery, 830 mAh | Lithium-polymer rechargeable battery, 1500 mAh |
| Ambient temperature      | 0–50°C  | 0–50°C   |
| Dimensions approx.       | 245 x 125 x 20 mm                             | 975 x 604 x 243 mm                             |
| Weight                   | approx. 70 g                                  | approx. 75 g                                   |

**EZL 2020-20 L charging case (Cat. No. 500542)**

|   |                            |
|---|----------------------------|
| Ambient temperature during charging                             | 0–40°C                     |
| Mains voltage   | 100–240 VAC (50/60 Hz)     |
| Primary power consumption                                       | max. 70 W                  |
| Charging voltage for HDE 2020 D                                 | typ. 5 V                   |
| Charging current per charging compartment for HDE 2020 D        | typ. 400 mA                |
| Charging time HDE 2020 D  | approx. 2.5 hrs            |
| Charging time EK 2020 D   | approx. 5 hrs              |
| Charging voltage for SK 2020 / BA 2015                          | max. 3.4 V                 |
| Charging current per charging compartment for SK 2020 / BA 2015 | typ. 500 mA                |
| Charging time SK 2020 / BA 2015                                 | approx. 3.5 hrs            |
| Dimensions  | approx. 600 x 270 x 380 mm |
| Weight (empty)  | approx. 8.3 kg             |

The Tourguide System 2020 D complies with the following European standards:

Radio: ETSI EN 301357-1/-2, class 1  
EMC: ETSI EN 301489-1/-9, EN 55103-1/-2  
Safety: EN 60065

**CE 0682**

Devices that operate in the 863–865 MHz frequency range can be used license-free in the following countries: A, B, BG, CH, CY, CZ, D, DK, E, EST, F, FIN, FL, GB, GR, H, HR, I, IRL, IS, L, LT, LV, M, N, NL, P, PL, S, SK, SLO, TR.

The Tourguide System 2020 D-US complies with the following US and Canadian standards:

USA: FCC-Part 15 B+C      Canada: RSS-210  
SK 2020 and HDE 2020: FCC ID: DMOTG 2020D, IC: 2099A - TG 2020 D  
SKM 2020: FCC ID: DMO SKM 2020 D; IC: 2099A - SKM 2020 D  
EK 2020 D: IC: 2099A - EK 2020 D

# Accessories

| Product name   | Product description  | Cat. No. |
|----------------|--|----------|
| HDE 2020 D     | Stethoset receiver   | 500543   |
| HDE 2020 D-US  | Stethoset receiver (US)  | 500544   |
| –              | Earbuds for HDE 2020 D and HDE 2020 D-US (black) stethoset receivers       | 037080   |
| –              | Earbuds for HDE 2020 D and HDE 2020 D-US (transparent) stethoset receivers | 040949   |
| EK 2020 D      | Receiver   | 502035   |
| EK 2020 D-US   | Receiver   | 502036   |
| EZT 3012       | Induction loop   | 504061   |
| GP 3000 L      | Lanyard  | 005224   |
| SK 2020 D      | Bodypack transmitter   | 500548   |
| SK 2020 D-US   | Bodypack transmitter (US)  | 500549   |
| SKM 2020 D     | Radio microphone   | 500894   |
| SKM 2020 D-US  | Radio microphone (US)  | 500895   |
| EZL 2020-20 L  | Charging case  | 500542   |
| BA 2015        | Accupack   | 009950   |
| CL 1           | Connecting cable for external audio devices (line input), 52 cm            | 005022   |
| ME 2-N         | Clip-on microphone   | 005018   |
| ME 4-N         | Clip-on microphone   | 005020   |
| MKE 2-EW GOLD  | Clip-on microphone   | 009831   |
| ME 3-N         | Headmic  | 005019   |
| HSP 2-EW       | Headmic  | 009866   |
| HSP 4-EW       | Headmic  | 009867   |
| HS 2-EW        | Headmic  | -        |
| EU mains cable | Mains cable with EU plug, 1.8 m, black                                     | 054324   |
| US mains cable | Mains cable with US plug, 1.8 m, black                                     | 054325   |
| UK mains cable | Mains cable with UK plug, 1.8 m, black                                     | 057256   |

# Manufacturer declarations

## Warranty

The original Sennheiser product you have purchased is covered by a warranty of 24 months. The warranty period begins on the date of purchase of brand new, unused products by the first end user. Please retain your sales receipt (or your warranty certificate) as proof of purchase. Unless you submit proof of purchase, which will be verified by your local Sennheiser service partner, you will be obliged to pay for any repairs that are carried out. Proof of purchase must state the date of purchase and name of the product.

We shall satisfy our warranty obligations by remedying any material or manufacturing faults free of charge at our discretion either by repair or by exchanging individual parts or the entire appliance. Any defective parts removed from a product during the course of a warranty claim shall become the property of Sennheiser electronic GmbH & Co. KG.

The following cases are not covered by the above warranty:

- minor faults or deviations in the quality of a product which do not affect the product's value or fitness for its intended purpose
- any accessories supplied with the product
- rechargeable and disposable batteries (these products have a shorter service life, the length of which also depends on the frequency of use)
- faults resulting from improper use (e.g. operating errors, mechanical damage, incorrect operating voltage)

Proper use for the purposes of this warranty is defined as use of the product under the conditions stated in the instructions for use.

- faults due to wear and tear
- any modification of Sennheiser products effected by you or a third party, unless Sennheiser has given its prior written consent to the nature and extent of the modification
- faults due to force majeure
- faults of which the purchaser was already aware at the time of purchase

All warranty claims become void if the product is tampered with by unauthorised persons or repair shops.

Warranty claims can be enforced in any country throughout the world in which the statutory rights of the country concerned are not in conflict with our warranty regulations. No other warranty claims or claims over and above the rights stated in these terms and conditions will be accepted.

Consumers may be entitled to statutory rights in their own countries which are not restricted by these warranty terms and conditions, as the warranty is governed by the laws of the country in which the Sennheiser product was purchased by the consumer. The provisions of the UN Convention on the International Sale of Goods do not apply to this service.

If you wish to file a claim under the warranty, please send the product to your local service partner, together with accessories and proof of purchase.

An up-to-date list of all service partners of Sennheiser electronic GmbH & Co. KG worldwide are available on the internet at [www.sennheiser.com](http://www.sennheiser.com).

### Statements regarding FCC and Industry Canada

This device complies with Part 15 of the FCC Rules and with RSS-210 of Industry Canada. Operation is subject to the following two conditions: (1) this device may not cause harmful interference, and (2) this device must accept any interference received, including interference that may cause undesired operation.

This equipment has been tested and found to comply with the limits for a Class B digital device, pursuant to Part 15 of the FCC Rules. These limits are designed to provide reasonable protection against harmful interference in a residential installation. This equipment generates, uses and can radiate radio frequency energy and, if not installed and used in accordance with the instructions, may cause harmful interference to radio communications. However, there is no guarantee that interference will not occur in a particular installation. If this equipment does cause harmful interference to radio or television reception, which can be determined by turning the equipment off and on, the user is encouraged to try to correct the interference by one or more of the following measures:

- Reorient or relocate the receiving antenna.
- Increase the separation between the equipment and receiver.
- Connect the equipment into an outlet on a circuit different from that to which the receiver is connected.
- Consult the dealer or an experienced radio/TV technician for help.

This class B digital device complies with the Canadian ICES-003.

Changes or modifications made to this equipment not expressly approved by Sennheiser electronic Corp. may void the FCC authorization to operate this equipment.

Before putting the device into operation, please observe the respective country-specific regulations!

## CE Declaration of Conformity

**CE 0682**

This equipment is in compliance with the essential requirements and other relevant provisions of the Directives 2004/108/EC, 2006/95/EC and 1999/05/EC. The declaration is available on the Internet at [www.sennheiser.com](http://www.sennheiser.com). Before putting the equipment into operation, please observe the respective country-specific regulations!

## Batteries or rechargeable batteries



The supplied batteries or rechargeable batteries can be recycled.

Please dispose of them as special waste or return them to your specialist dealer. In order to protect the environment, only dispose of exhausted batteries.

## WEEE Declaration



Your Sennheiser product was developed and manufactured with high-quality materials and components which can be recycled and/or reused. This symbol indicates that electrical and electronic equipment must be disposed of separately from normal waste at the end of its operational lifetime.

Please dispose of this product by taking it to your local collection point or recycling centre for such equipment. This will help to protect the environment in which we all live.

# Index

## **Bodypack transmitter 10**

- Activating/deactivating the lock mode 45
- Changing the sensitivity of the line input 41
- Changing the sensitivity of the microphone input 42
- Charging the rechargeable battery 32
- Connecting a microphone 27
- Connecting external audio sources 28
- Displaying the transmission frequency 44
- Displaying the version number 47
- Inserting/changing the batteries/accupack 27
- Loading the factory-preset default settings 45
- Setting the channel 35
- Switching off 29
- Switching on 29
- Switching the line input on/off 40

## **Charging case 14**

- Connecting 25
- LED indication for charging compartments for accupack/bodypack transmitter 22
- Setting up 25
- Switching off 30
- Switching on 30

## **Indications and displays 15**

- Automatic copying (charging case) 21
- Battery status display (receiver) 20
- Channel display (receiver) 20
- Charge status LED (receiver) 19
- Lock mode icon 16, 17
- MUTE (bodypack transmitter) 16
- Operation and battery status indication (bodypack transmitter) 15
- Operation and battery status indication (radio microphone) 17
- Operation indication (charging case) 21
- Peak LED (bodypack transmitter) 15
- RF signal indication (receiver) 19
- Temperature indication (charging case) 21
- Volume display (receiver) 20

**Radio microphone 11**

- Activating/deactivating the lock mode 45
- Adjusting the input sensitivity 43
- Displaying the transmission frequency 44
- Displaying the version number 47
- Inserting/changing the batteries/accupack 26
- Loading the factory-preset default settings 45
- Setting the channel 35
- Switching off 29
- Switching on 29

**Receiver 12**

- Adjusting the volume 31
- Battery status display 20
- Channel display 20
- Charge status LED 19
- Charging the rechargeable battery 33, 34
- Copying channels to other receivers (copy function) 37
- RF signal indication 19
- Setting the channel 37
- Switching on/off 30
- Volume display 20



Sennheiser electronic GmbH & Co. KG  
Am Labor 1, 30900 Wedemark, Germany  
[www.sennheiser.com](http://www.sennheiser.com)

Printed in Germany  
Publ. 09/09  
516509/A04